



legalSHPi

Multi mode legaliser
31/05/06 v0.05

user manual

Table of Contents

1 System Overview	4
1.1 Legaliser Processing	4
1.2 Proc Amp	5
1.3 Legaliser	5
1.3.1 Composite Mode	5
1.3.2 RGB Mode	5
1.3.3 YUV Mode	6
1.3.4 Clip & Knee	6
1.3.5 Ring Suppression	8
1.4 Monitoring Output Generation	9
1.4.1 Logging	10
2 Installation	11
2.1 Connections to a legalSHPi	11
2.2 Associated Equipment for the legalSHPi	11
3 Control Panel	12
4 Operation	14
4.1 Manual control of the legalSHPi	14
4.2 Automation Control of the legalSHPi	14
4.3 Operational Menus for the legalSHPi	14
5 PC Logging Application	35
5.1.1 Installation	35
5.1.2 Setting Up for Logging	35
5.1.3 Understanding the Application	35

Table of Figures

Figure 1 - Basic Legaliser Structure	4
Figure 2 - Composite Legaliser Structure	5
Figure 3 - RGB Legaliser Structure	6
Figure 4 - YUV Legaliser Structure	6
Figure 5 - Illegal Source	7
Figure 6 - Hard Clipped Output.....	7
Figure 7 - Soft Clipped Output	8
Figure 8 - Legal Signal Showing Ringing Undershoots	9
Figure 9 - Ring Suppression On	9
Figure 10 - Typical Connections	11
Figure 11 - evolutionDT Control Panel.....	13
Figure 12 - Logging Application GUI.....	36

1 System Overview

The legalSHPi is a full-featured multi-mode legaliser system using the evolutionDT platform. The main features of the legalSHPi series of legalisers are as follows:

- Provides Legalisation of the SDI Input signal with full 10 bit processing throughout.
- Composite, YUV and RGB colour spaces
- Two Independent SDI outputs for "Legalise" and user controllable "Legal/Indicate".
- Adjustable Clipping Levels.
- Adjustable soft clipping knee levels. (RGB and YUV).
- Highly effective overshoot and undershoot suppression on the luminance signal.
- EDH re-insertion
- Integral luma and chroma gain, black level adjustment & hue rotation.
- EBU 2003 standard legalisation settings.
- 7.5 IRE or 0 IRE Pedestal.
- 6 User Memories.
- Log output with Timecode and PC viewer programme.
- Unique severity display mode on monitoring output.

1.1 Legaliser Processing

A Block diagram of the legaliser is shown in Figure 1. Each section is discussed below.

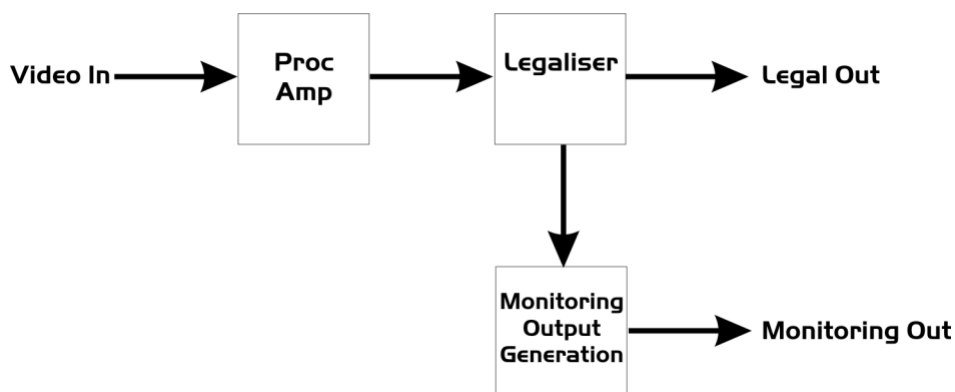

Figure 1 - Basic Legaliser Structure

1.2 Proc Amp

This enables the luma gain to be adjusted from 0 to 200%, Similarly the chroma also is adjustable from 0 to 200%. Full 10 bit by 10 bit Multipliers are used with a rounded 10 bit product. Black level adjustment is also applied at this point as is hue adjustment which allows for $\pm 180^\circ$ of hue rotation. These controls are accessed via the "Picture" menu.

1.3 Legaliser

The legaliser operates in one of three modes; RGB, YUV or Composite. The mode is selected via the top level mode menu. Each mode is discussed below. In all modes the legaliser is transparent to pixels within the legal range.

1.3.1 Composite Mode

The basic form of the composite legaliser is shown in Figure 2. In composite mode the legaliser restricts the Y, U & V components such that when the signal is converted to a composite waveform the Y component stays within the range allowed by the Y High Clip and Y Low Clip and the total composite waveform stays within the range defined by Comp High Clip and Comp Low Clip.

The legaliser works by selectively reducing the saturation of pixels which would otherwise result in over modulation of the composite waveform. Composite mode preserves the hue of each pixel but not the saturation.

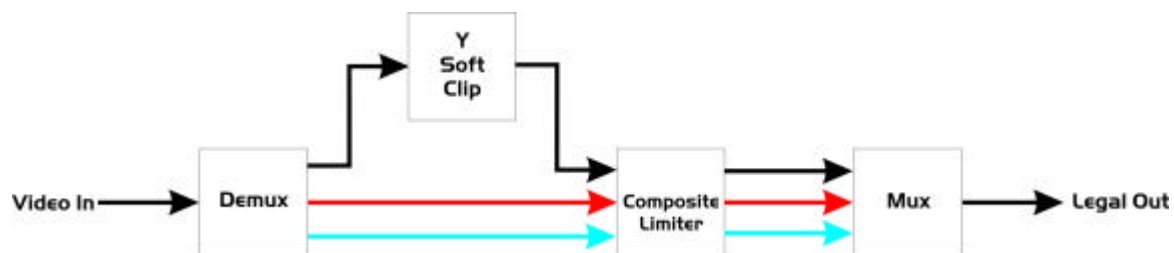

Figure 2 - Composite Legaliser Structure

1.3.2 RGB Mode

The basic form of the RGB legaliser is shown in Figure 3. In RGB mode the legaliser first converts the video from the YUV colour space to the RGB colour space. The RGB data is then soft clipped according to the settings for RGB High Clip & Knee and RGB Low Clip & Knee. Finally the clipped RGB data is converted back to the YUV colour space. The RGB legal colour space is a subset of the composite legal colour space so an RGB legal signal is also composite legal but the reverse is not true.

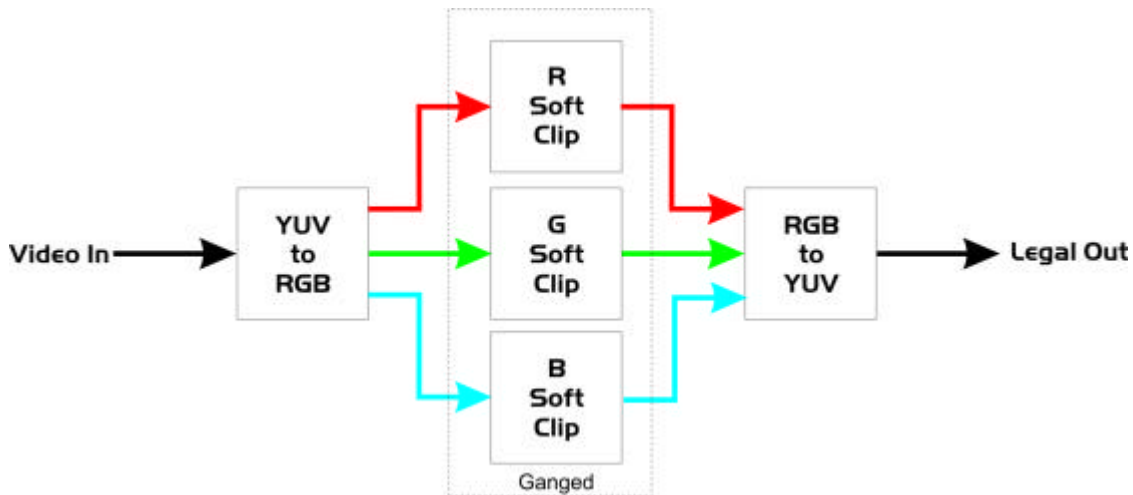

Figure 3 - RGB Legaliser Structure

1.3.3 YUV Mode

The basic form of the YUV legaliser is shown in Figure 4. In YUV mode the legaliser provides direct clipping of the raw YUV data using separate clip and knee parameters for the Y and colour difference components.

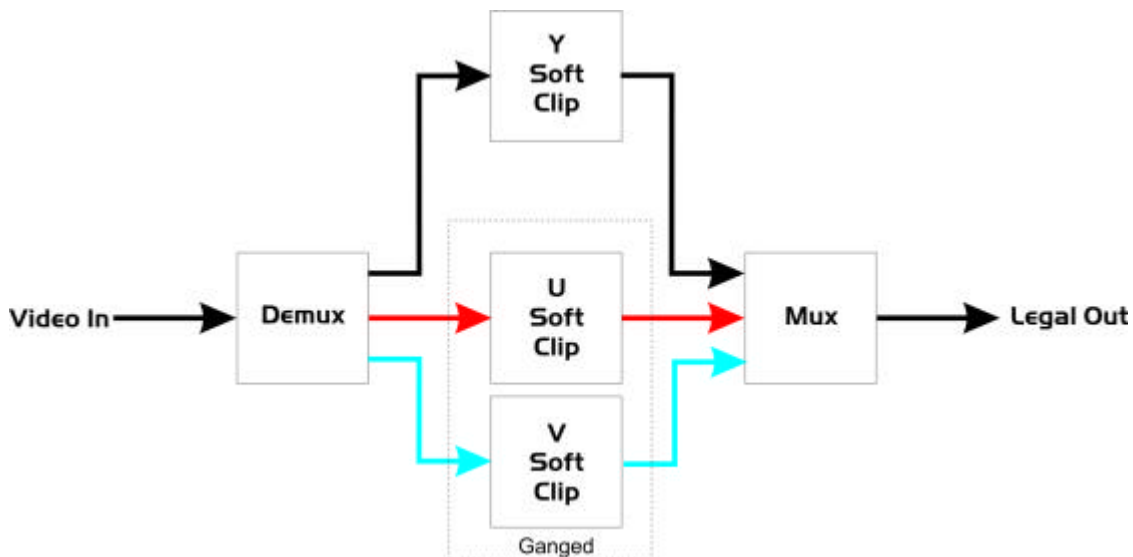

Figure 4 - YUV Legaliser Structure

1.3.4 Clip & Knee

Many of the legaliser functions present Clip and Knee parameters to the user. The Clip parameters specify the maximum and minimum values the system legaliser will allow to pass. Figure 5 shows an illegal input to the clipper with detail in the illegal highlight and lowlight areas of the signal. When the knee values are set to the same value as their respective Clips the legaliser operates as a hard-clipper as shown in Figure 6 show shows the now legal signal but the detail in the highlights and lowlights has been lost. Figure 7 shows the same input signal legalised with a 10% difference between the Clips and their respective Knees. The highlight/lowlight detail has been compressed into the legal region at the expense of some of the dynamic range of the originally legal part of the waveform.



Figure 5 - Illegal Source



Figure 6 - Hard Clipped Output

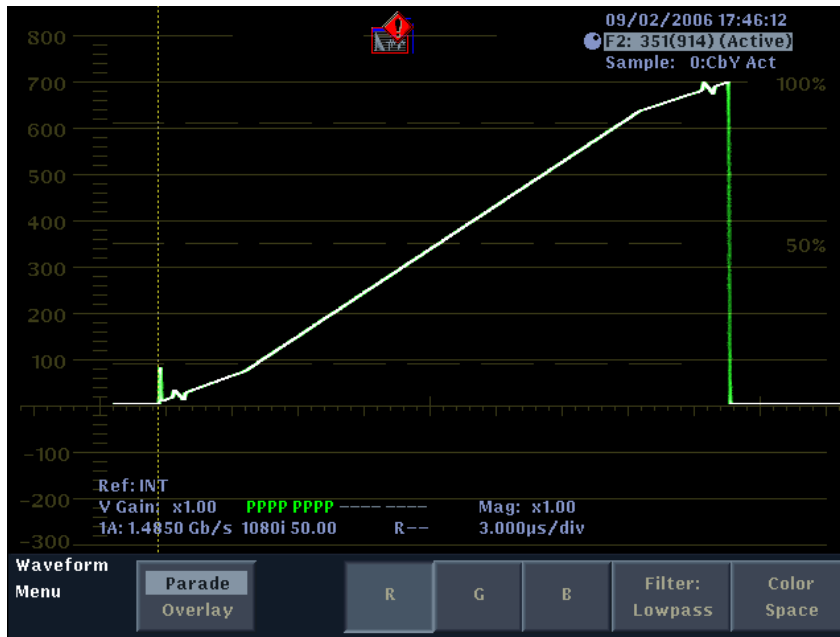

Figure 7 - Soft Clipped Output

1.3.5 Ring Suppression

The legalSHPi also features a proprietary ring-suppression function which can be used to reduce the visual artefact of apparent overshoots on legal signals when viewed on a waveform monitor. Figure 8 shows a close up of a legal signal featuring fast transitions between light and dark areas and showing some apparent undershoots when viewed on a waveform monitor. These undershoots are caused by the bandwidth limiting inherent in analog waveform monitors and also necessary in digital waveform monitors to smoothly interpolate the waveform from the discrete time samples provided by the input video.

Turning on the ring suppression function introduces an adaptive predictive filter which band limits on those transitions likely to cause ringing to occur outside of the legal region and results in a significant reduction in visible overshoot/undershoot ringing as shown in Figure 9.

N.B. Because ring suppression is implemented by an adaptive predictive filter it can lead to visual artefacts on some source material in which case it should be disabled.

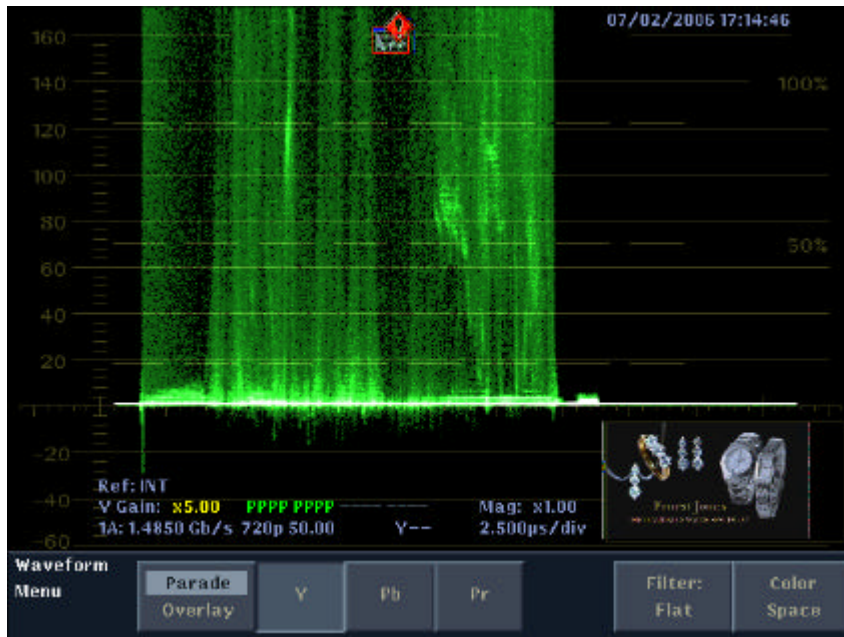

Figure 8 - Legal Signal Showing Ringing Undershoots

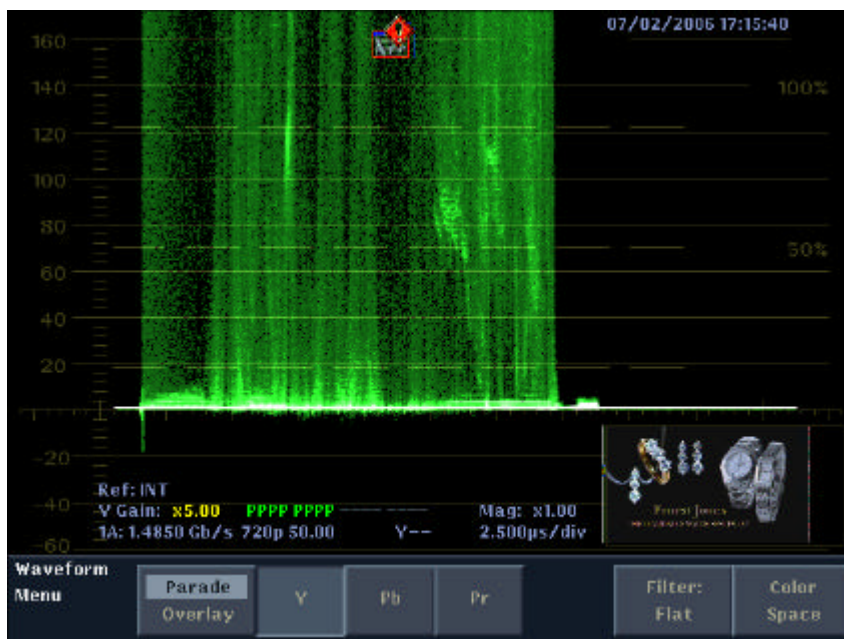

Figure 9 - Ring Suppression On

1.4 Monitoring Output Generation

The second output of the legaliser can be configured either as a second legal output or to display which areas of the picture are being processed by the legaliser. The “MonOp” menu provides control of this feature and allows the user to select which colour is used to represent the processed picture area.

When used as an indicate output the selected colour is keyed over the legal output with the opacity of the colour indicating how illegal the area is. Because signals are typically only slightly illegal the gain on the keyer can be controlled to

deliver the desired mix. The gain is controlled by the “Gamut Gain” menu and setting this menu to its maximum value will give the same output as a traditional indicate output.

1.4.1 Logging

In addition to the visual monitoring output the legalSHPi provides a timecode stamped log output via the RS-232 connector which can be connected to a PC running the optional logging application (see section 5 for further details).

2 Installation

2.1 Connections to a legalSHPi

Figure 10 shows the typical connections to the legalSHPi.

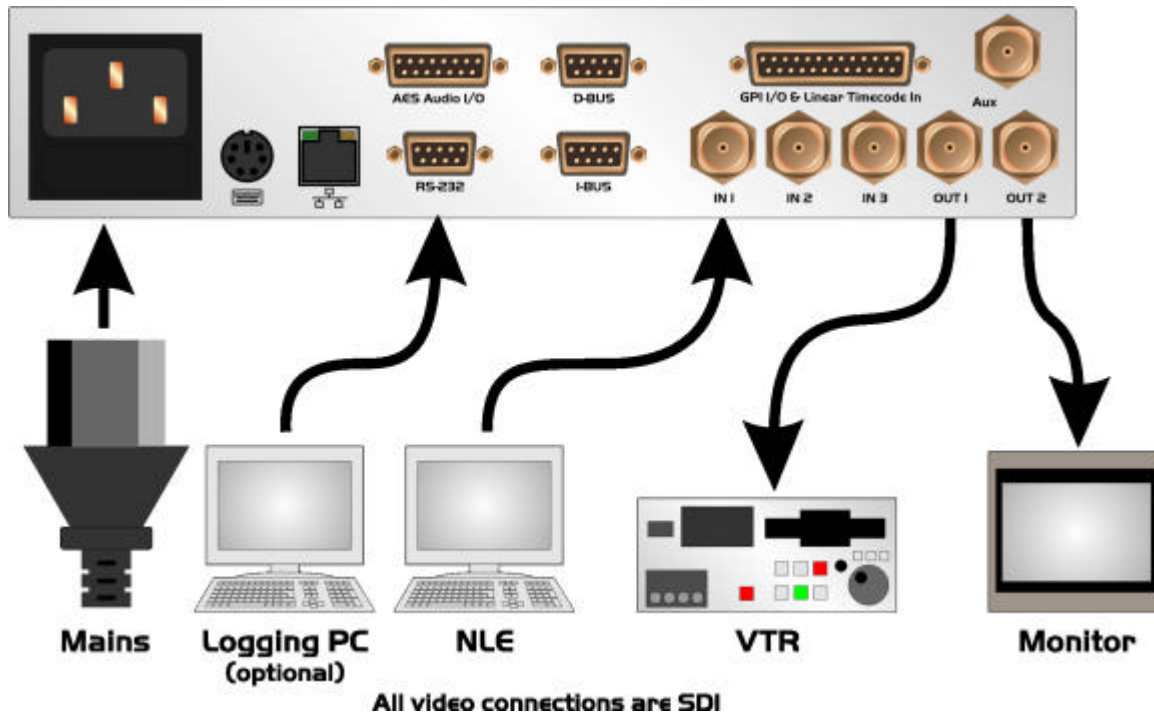

Figure 10 - Typical Connections

IN1 is the SDI input. OUT1 is the main SDI legalised output. OUT2 is the SDI monitoring output which can be switched to show either the legalised output or the indicate display.

2.2 Associated Equipment for the legalSHPi

The legalSHPi in the evolutionDT platform is fully self-contained. The evolutionDT can optionally be rack mounted in with 1 or 2 units in a 19" rack using the optional FF-6 rack mounting. This is a factory-installed option and should be ordered with the product. Rack mounted units should be supported with suitable chassis supports.

3 Control Panel

Figure 11 shows the control panel of the evolutionDT platform.

1 - Power/Status LED

Green – Normal operation

Green Flashing - Version Information Display

Orange – Product is initialising

Flashing Red – Product is in Field Reprogramming Mode

2 - Menu Display/Button (1 of 4)

Displays Menu Information. The colour of the menu button indicates the function.

Green – adjustment menu. Pressing the menu or using the associated digipot(6) will adjust the menu value.

Yellow – information menu, no adjustment possible.

Blue – navigation menu. Pressing the button will take you up or down the menu hierarchy.

Red – multiple variable menu. Pressing the button will “open” the menu assigning one digipot(6) to each variable. The active LED(5) will light above the digipots associated with each variable.

3 - Next Menu Button

Within a layer of the menu hierarchy there may be more than four menus and where this is the case the “next” button will illuminate to show that further menus are available. Pressing the “next” button moves you to the next set of menus.

4 – Previous Menu Button

Within a layer of the menu hierarchy there may be more than four menus and where this is the case the “prev” button will illuminate to show that previous menus are available. Pressing the “prev” button moves you to the previous set of menus.

5 – Digipot Active LED (1 of 4)

Illuminates to indicate that the digipot below is active for adjustment of the associated menu variable.

6 – Digipot (1 of 4)

Allows for rapid adjustment of the associated menu variable.

7 – Next Device Button

It is possible to control more than one device from a single evolutionDT control panel. Where more than one device is assigned to the panel the “next dev” will move control to the next device in the device list.

In setup mode this button will pick up a free device and assign it to this panels device list. The button will flash to indicate that a free device is selected.

8 – Previous Device Button

Where more than one device is assigned to the panel the “prev dev” will move control to the previous device in the device list.

In setup mode this button will remove a device owned by this panel from this panels device list. The button will flash to indicate an owned device is selected.

9 – Info Button

This button displays all hardware, software and firmware version information for the currently selected product and this panel.

In setup mode where a free evolutionDT device is selected this button will flash indicating that the network address (box & slot) can be changed. Pressing this button will take you to the adjustment menus.

10 – Setup Button

Press and hold this button for four seconds to enter setup mode.

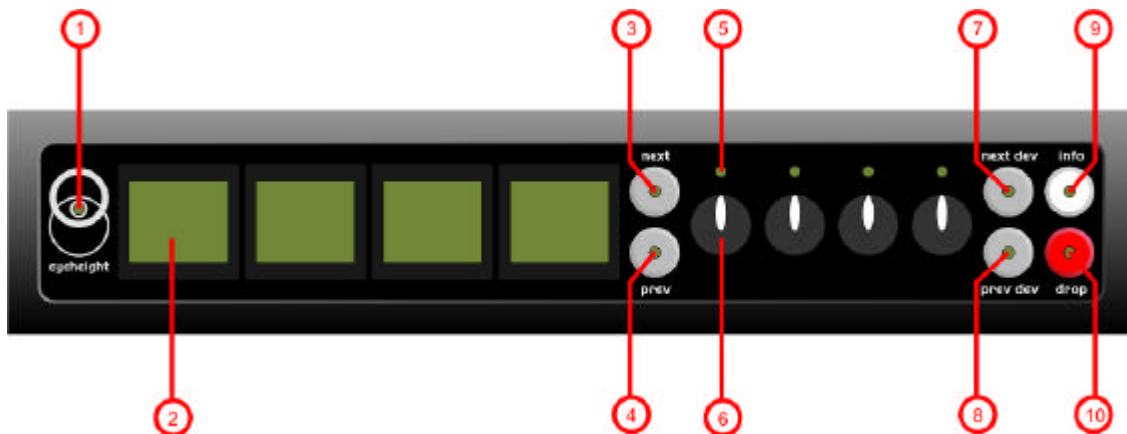

Figure 11 - evolutionDT Control Panel

4 Operation

4.1 Manual control of the legalSHPi

The legalSHPi is controlled using a set of MENUS. Each of these menus contains up to 3 parameters that are adjusted using the rotary digipots. The Menus define all of the adjustable operational parameters in the legalSHPi.

See chapter 3 Control Panel Operation for details of the control panel operation.

See section 3 of this chapter for the full list of menus.

4.2 Automation Control of the legalSHPi

Automation of the evolutionDT products is achieved either via the RS232 port (currently not implemented) or via the I-Bus Port using an optional DG-9 (RS232 to I-Bus dongle). Automation control of the legalSHPi is performed using the geNETics Automation Protocol.

Genetics protocol is described in detail in the “geNETics User Guide” section titled “Automation Protocol on the geNETics Platform”. The menu list in section 3 of this chapter contains the data information for the protocol.

Please refer to the “User guide for the DG-9 eyeheight dongle and set-up software.

4.3 Operational Menus for the legalSHPi

Menu 00-03: Top Level Menus

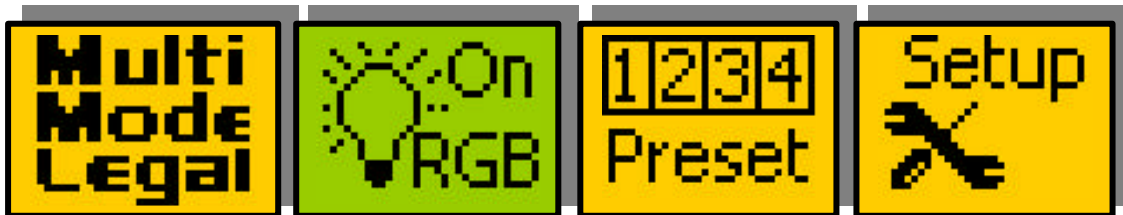

Menu Num.	Heading	Automation	Function
00	Product Name	none	Press this to display the product software version.

01	MODE	OFF RGB YUV COMP [0→3]	Selects the legaliser modes
02	PRESET	none	Go to the main Preset menus (4-7)
03	SETUP	none	Go to the main Setup menus (8-11)

Menu 04-07: Preset Menus



Menu Num.	Heading	Automation	Function
04	USER PRESET	none	Go to the User Preset menus (20-35)
05	STND PRESET	none	Go to the Standard Preset menus (12-19)
06		none	
07	BACK	none	Back to the main operational menus (0-3)

Menu 08-11: Setup Menus

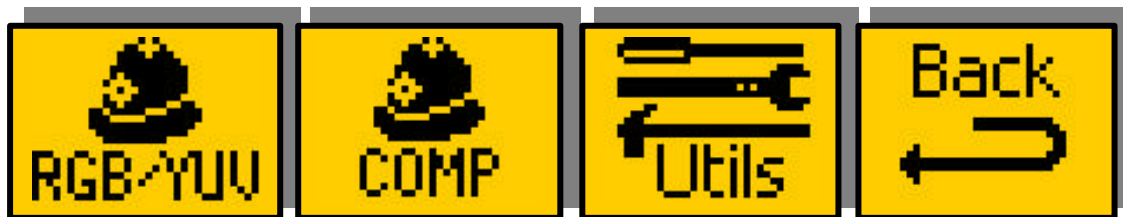

Menu Num.	Heading	Automation	Function
08	RGB/YUV	none	Got to the RGB/YUV main menus (36-39)

09	COMP	none	Go to the main COMP menus (80-83)
10	UTILS	none	Go To the main Utility menus (92-99)
11	BACK	none	Back to the main Operation menus (0-3)

Menus 12-15: Presets

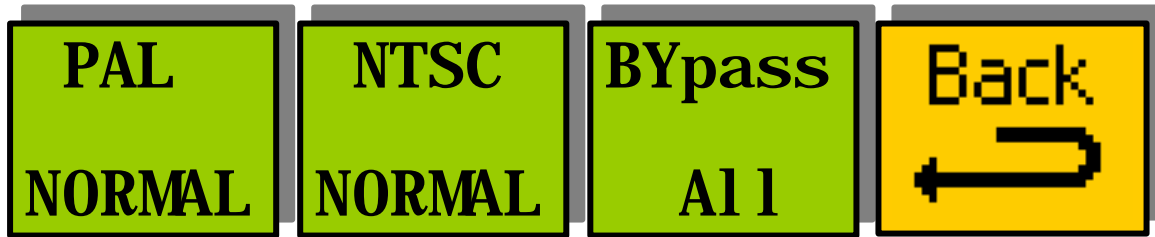

Menu Num.	Heading	Automation	Function
12	PAL NORMAL Preset Setting	1=Recall (Variable 1)	Pressing this will Set The system to Composite Clipping: Hi Y Clip = +700mv Hi Comp Clip = +931mv Lo Y Clip = +0mv Lo Comp Clip = -230
13	NTSC NORMAL Preset Setting	1=Recall (Variable 1)	Pressing this will Set The system to Composite Clipping: Hi Y Clip = +100 IRE Hi Comp Clip = +120 IRE Lo Y Clip = +0mv Lo Comp Clip = -170mv Pedestal = 7.5
14	Bypass All	1=Recall (Variable 1)	Pressing this will Set The Legaliser to OFF
15	BACK	none	Go back to the main Preset menus (4-7)

Menus 16-19: Presets

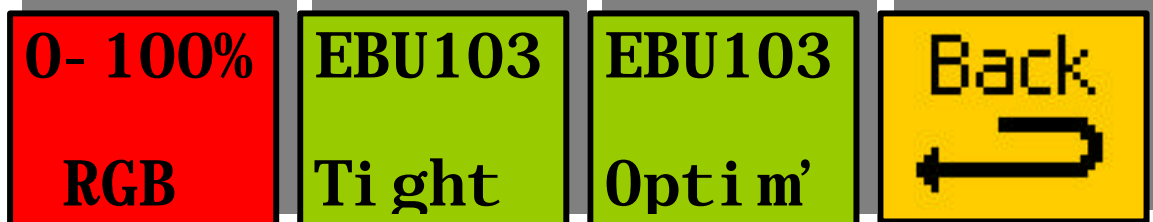

Menu	Heading	Automation	Function
16	0-100% RGB Preset Setting	1=Recall	Pressing this will Set The system to RGB Clipping: Hi RGB Clip = 100% Lo RGB Clip = 0.0% Ring Suppression = OFF
17	EBU Rec 103 Tight Setting	1=Recall (Variable 1)	Pressing this will Set The system to RGB Clipping and Luma Clipping: Hi RGB Clip = 105% Lo RGB Clip = -5% Hi Luma Clip = 103% Lo Luma Clip = -1% Ring Suppression = YCLIP These settings represent the exact requirements of EBU Rec 103.
18	EBU Rec 103 Optimum Setting	1=Recall (Variable 1)	Pressing this will Set The system to RGB Clipping and Luma Clipping: Hi RGB Clip = 103% Lo RGB Clip = -3% Hi Luma Clip = 101% Lo Luma Clip = 0% Ring Suppression = YCLIP These settings meet the requirements of EBU Rec 103, but pull the settings into a “more” legal setting. This might be regarded as a “safer” setting than meeting EBU 103 exactly.
19	BACK	none	Go back to the main Preset menus (4-7)

Menus 20–23: Memory Controls

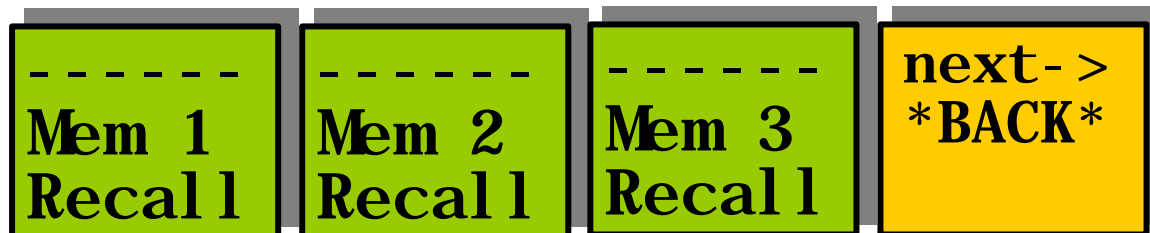

Menu Num.	Heading	Automation	Function
20	MEM1	1=Recall (Variable 1)	Pressing this will recall Memory number 1. User Names can be programmed in to the memories using a keyboard. See "geNETics User guide", section "Giving product Memories names"
21	MEM2	1=Recall (Variable 1)	Pressing this will recall Memory number 2.
22	MEM3	1=Recall (Variable 1)	Pressing this will recall Memory number 3.
23	BACK	none	Got to the Main Preset menus (4-7)

Menus 24-27: Memory Controls

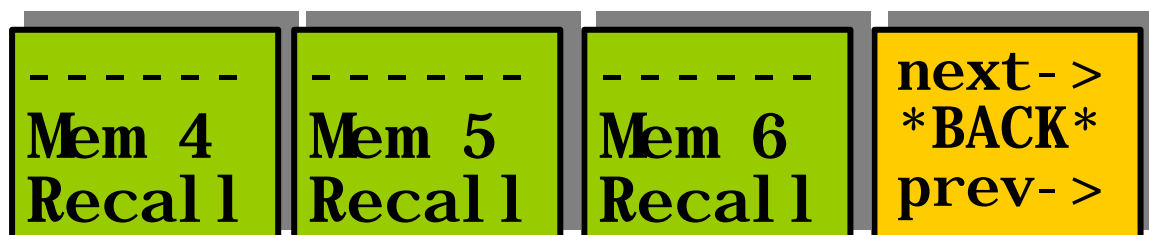

Menu Num.	Heading	Automation	Function
24	MEM4	1=Recall (Variable 1)	Pressing this will recall Memory number 4.
25	MEM5	1=Recall	Pressing this will recall Memory

		(Variable 1)	number 5.
26	MEM6	1=Recall (Variable 1)	Pressing this will recall Memory number 6.
27	BACK	none	Go to the main Preset menus (4-7)

Menu 28-31: Memory Controls

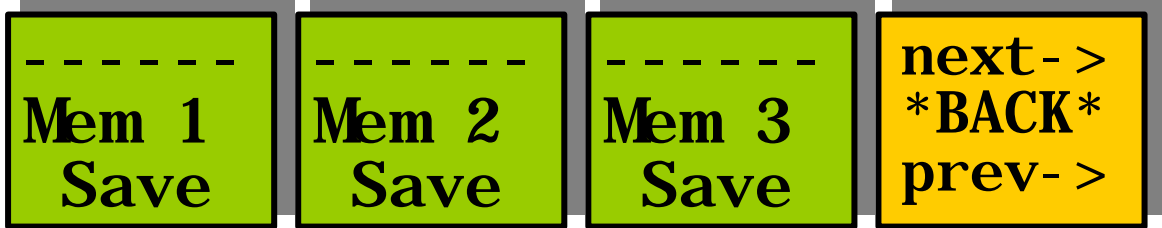

Menu Num.	Heading	Automation	Function
28	Save Mem. #1	1= Save	Pressing this will Save Memory number 1.
29	Save Mem. #	1= Save	Pressing this will Save Memory number 2.
30	Save Mem. #3	1= Save	Pressing this will Save Memory number 3.
31	BACK	none	Go to the main Preset menus (4-7)

Menu 32-35: Memory Controls

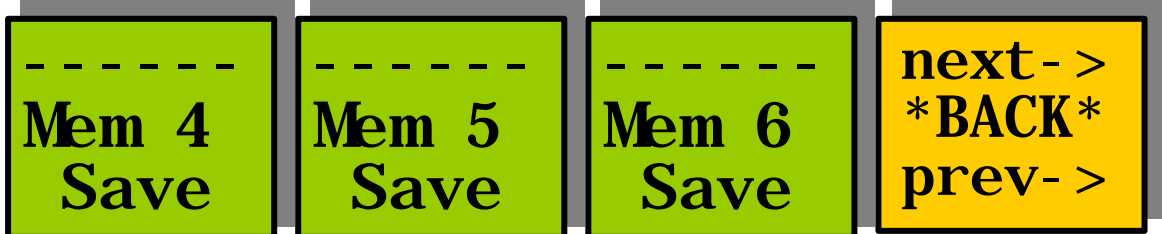

Menu Num.	Heading	Automation	Function
32	Save Mem. #5	1= Save	Pressing this will Save Memory number 4.

33	Save Mem. #6	1= Save	Pressing this will Save Memory number 5.
34	Save Mem. #7	1= Save	Pressing this will Save Memory number 6.
35	BACK	none	Go to the main Preset menus (4-7)

Menu 36-39: RGB/YUV Setup Menus

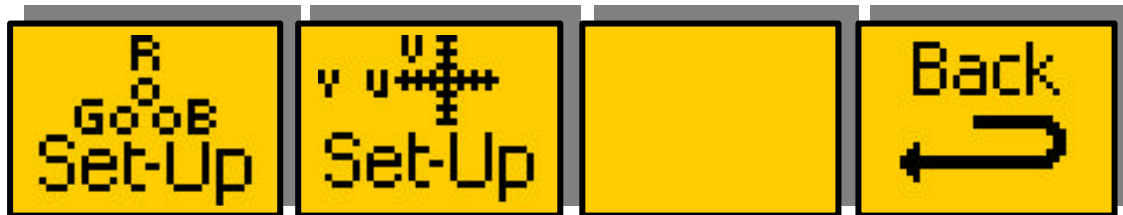

Menu Num.	Heading	Automation	Function
36	RGB Setup	none	Go to the RGB Setup menus (40-43)
37	YUV Setup	none	Go to the YUV Setup menus (52-55)
38	Blank	none	
39	BACK	none	Go to the Setup menus (6-8)

Menu 40-43: RGB Clip and Knee Menus

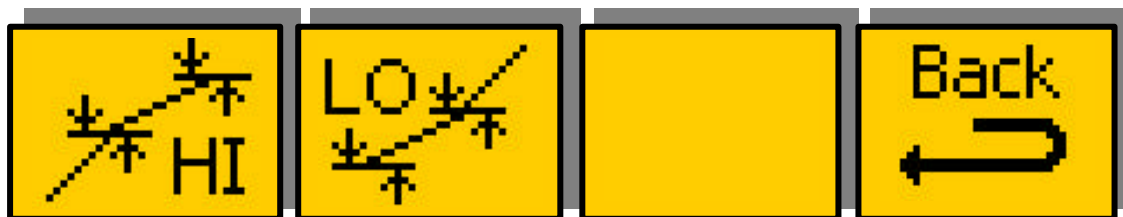

Menu Num.	Heading	Automation	Function
40	Hi	none	Go to the RGB Hi Clip and Hi Knee Clipping menus (44-47)
41	Lo	none	Go to the RGB Lo Clip and Lo Knee Clipping menus (48-51)
42		none	Blank
43	BACK	none	Go to the RGB/YUV menus (36-39)

Menus 44-47: RGB High Clip and Knee settings

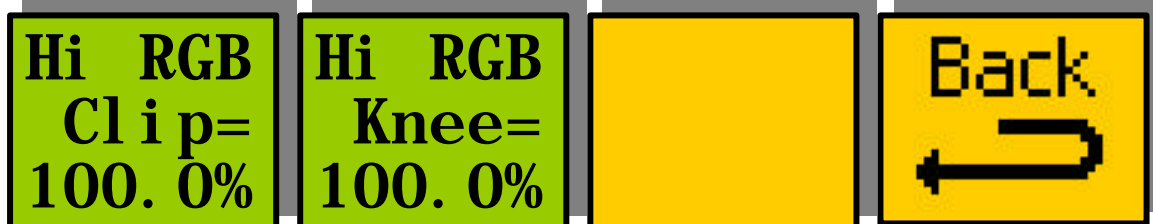

Menu Num.	Heading	Automation	Function
44	High Clip Level	51% → 109% [512→1023]	This indicates the High Clip point for the RGB Clipping. This is normally set to 100% for clipping at 0.7V in the analogue domain.
45	High Knee Level	51% → 109% [512→1023]	This indicates the High Knee point for the RGB Clipping. This can be set to give a “soft clip” from this knee point to the hard clip point.
46		none	Blank
47	BACK	none	Go to the RGB Clip and Knee menus (40-43)

Menu 48-51: RGB Low Clip and Knee Settings

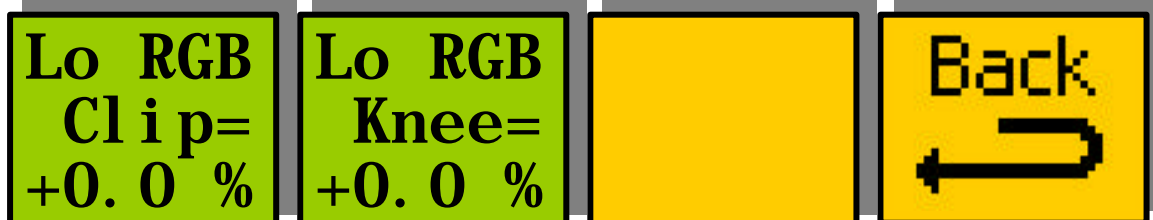

Menu Num.	Heading	Automation	Function
48	Low Clip Level	-7% → 50% [1→511]	This indicates the Low Clip point for the RGB Clipping. This is normally set to 0% for clipping at 0V in the analogue domain.
49	Low Knee Level	-7% → 50% [1→511]	This indicates the Low Knee point for the RGB Clipping. This can be set to give a “soft clip” from this knee point to the Low clip point.
50		none	Blank
51	BACK	none	Go to the RGB Clip and Knee menus (40-43)

Menu 52-55: YUV Clips

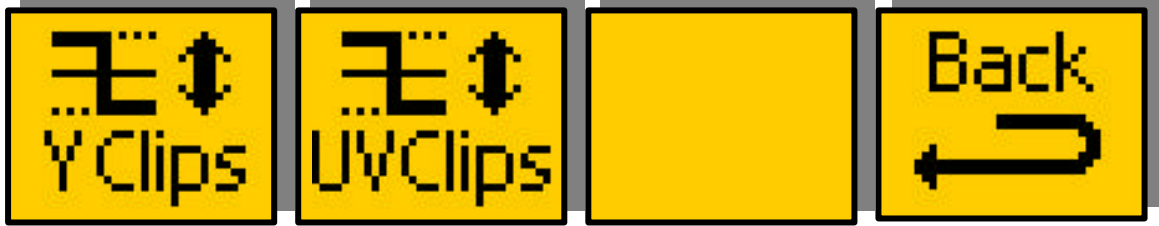

Menu Num.	Heading	Automation	Function
52	Y Clips	none	Go to the Y Clip and Knee menus (56-59)
53	Low Knee Level	none	Go to the UV Clip and Knee menus (68-71)
54		none	Blank
55	BACK	none	Go to the RGB/YUV menus (36-39)

Menu 56-59: YUV Y Clip and Knee Menus

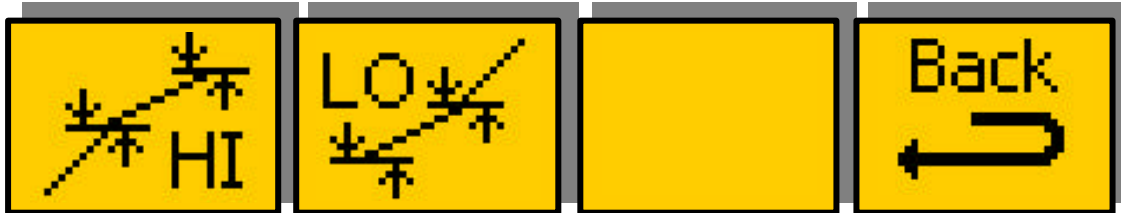

Menu Num.	Heading	Automation	Function
56	Hi	none	Go to the YUV Y Hi Clip and Hi Knee Clipping menus (44-47)
57	Lo	none	Go to the YUV Y Lo Clip and Lo Knee Clipping menus (48-51)
58		none	Blank
59	BACK	none	Go to the YUV menus (52-55)

Menus 60-63: YUV Y High Clip and Knee settings



Menu Num.	Heading	Automation	Function
60	High Clip Level	51% → 109% [512→1023]	This indicates the High Clip point for the YUV Y Clipping. This is normally set to 100% for clipping at 0.7V in the analogue domain.
61	High Knee Level	51% → 109% [512→1023]	This indicates the High Knee point for the YUV Y Clipping. This can be set to give a “soft clip” from this knee point to the hard clip point.
62		none	Blank
63	BACK	none	Go to the YUV Y Clip and Knee menus (56-59)

Menu 64-67: YUV Y Low Clip and Knee Settings

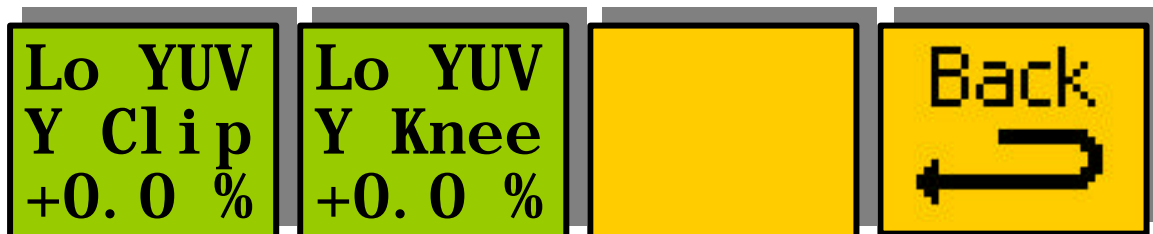

Menu Num.	Heading	Automation	Function
64	Low Clip Level	-7%→ 50% [1→511]	This indicates the Low Clip point for the YUV Y Clipping. This is normally set to 0% for clipping at 0V in the analogue domain.
65	Low Knee Level	-7%→ 50% [1→511]	This indicates the Low Knee point for the YUV Y Clipping. This can be set to give a “soft clip” from this knee point to the Low clip point.
66		none	Blank
67	BACK	none	Go to the YUV Y Clip and Knee menus (56-59)

Menu 68-71: YUV UV Clip and Knee Menus

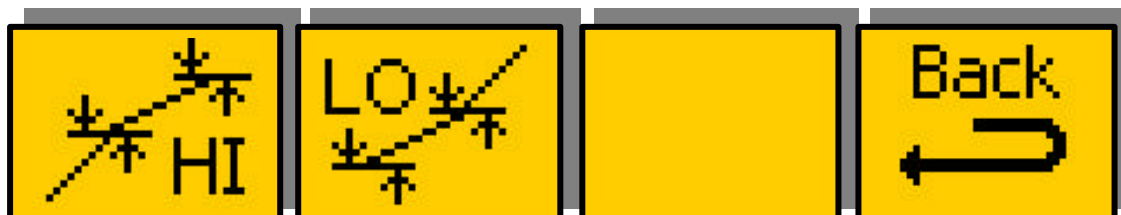

Menu Num.	Heading	Automation	Function
68	Hi	none	Go to the YUV UV Hi Clip and Hi Knee Clipping menus (72-75)
69	Lo	none	Go to the YUV UV Lo Clip and Lo Knee Clipping menus (76-79)
70		none	Blank
71	BACK	none	Go to the YUV menus (52-55)

Menus 72-75: YUV UV High Clip and Knee settings



Menu Num.	Heading	Automation	Function
72	High Clip Level	51% → 109% [512→1023]	This indicates the High Clip point for the YUV UV Clipping. This is normally set to 100% for clipping at 0.7V in the analogue domain.
73	High Knee Level	51% → 109% [512→1023]	This indicates the High Knee point for the YUV UV Clipping. This can be set to give a “soft clip” from this knee point to the hard clip point.
74		none	Blank
75	BACK	none	Go to the RGB Clip and Knee menus (68-71)

Menu 76-79: YUV UV Low Clip and Knee Settings

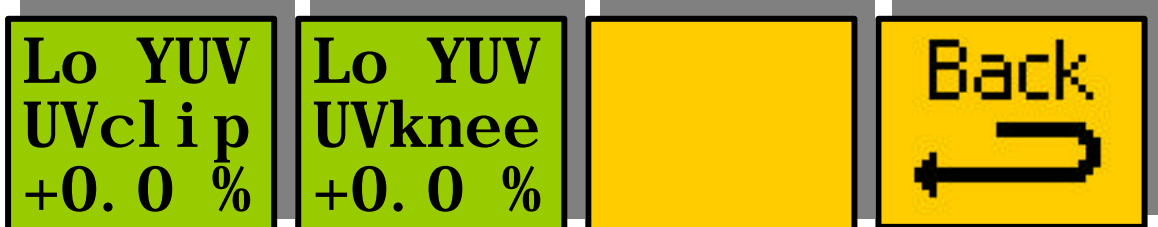

Menu Num.	Heading	Automation	Function
76	Low Clip Level	-7%→ 50% [1→511]	This indicates the Low Clip point for the YUV UV Clipping. This is normally set to 0% for clipping at 0V in the

			analogue domain.
77	Low Knee Level	-7% → 50% [1→511]	This indicates the Low Knee point for the YUV UV Clipping. This can be set to give a “soft clip” from this knee point to the Low clip point.
78		none	Blank
79	BACK	none	Go to the YUV UV Clip and Knee menus (68-71)

Menu 80-83: Composite Clip and Knee Menus (NTSC)

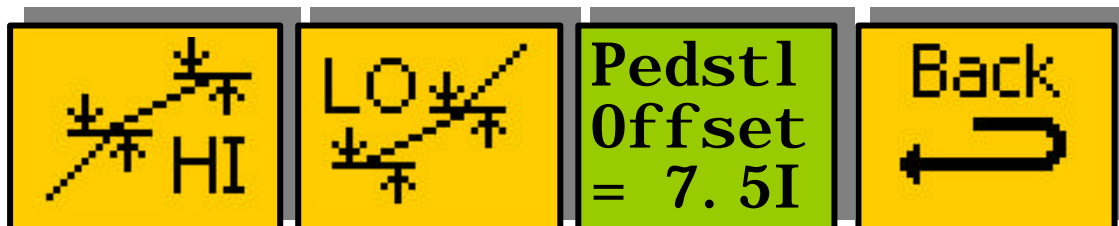

Menu Num.	Heading	Automation	Function
80	Hi	none	Go to the Composite Hi Clip and Hi Knee Clipping menus (84-87)
81	Lo	none	Go to the Composite Lo Clip and Lo Knee Clipping menus (88-91)
82	Pedestal	0.0I 7.5I [0:1]	Pedestal IRE setting. This can be set to 0.0 or 7.5 IRE.
83	BACK	none	Go to the Setup menus (8-11)

Menus 84-87: Composite High Clip and Knee settings (NTSC)

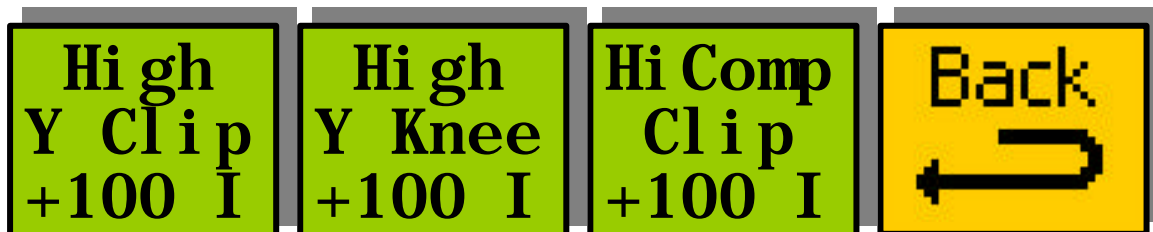

Menu Num.	Heading	Automation	Function
84	High Clip Level	[8-511]	This indicates the High Clip point for the Composite Luma Clipping.
85	High Knee Level	[8-511]	This indicates the High Knee point for the Composite Luma Clipping. This can be set to give a “soft clip” from this knee point to the hard clip point.

86	High Composite Clip Level	[8-511]	This indicates the High Clip point for the Composite Clipping.
87	BACK	none	Go to the Composite Clip and Knee menus (80-83)

Menu 88-91: Composite Low Clip and Knee Settings (NTSC)

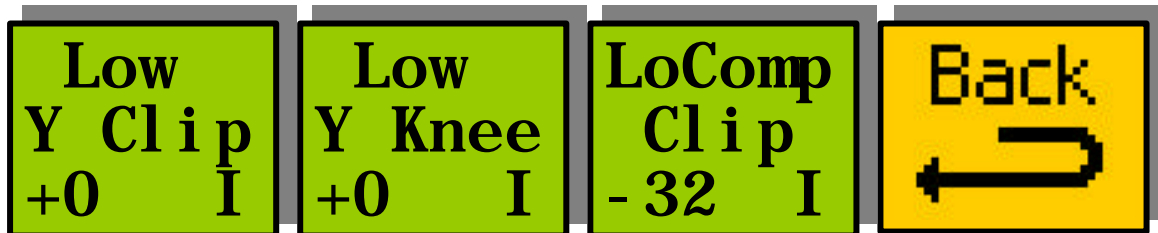

Menu Num.	Heading	Automation	Function
88	Low Clip Level	[8→511]	This indicates the Low Clip point for the Composite Luma Clipping.
89	Low Knee Level	[8→511]	This indicates the Low Knee point for the Composite Luma Clipping. This can be set to give a “soft clip” from this knee point to the hard clip point.
90	Low Composite Clip Level	[8→511]	This indicates the Low Clip point for the Composite Clipping.
91	BACK	none	Go to the Composite Clip and Knee menus (80-83)

Menu 80-83: Composite Clip and Knee Menus (PAL)

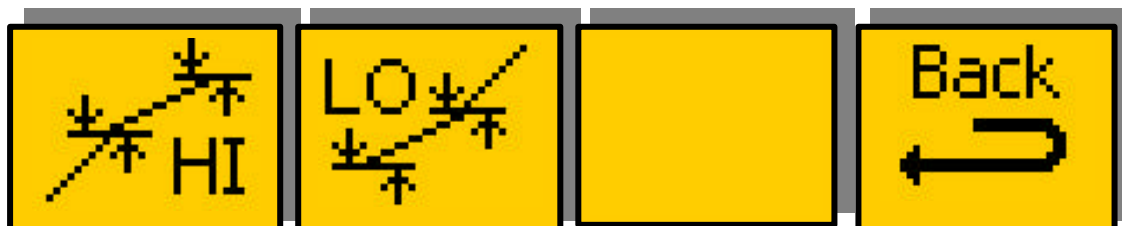

Menu Num.	Heading	Automation	Function
80	Hi	none	Go to the Composite Hi Clip and Hi Knee Clipping menus (84-87)
81	Lo	none	Go to the Composite Lo Clip and Lo Knee Clipping menus (88-91)
82		none	Blank
83	BACK	none	Go to the Setup menus (8-11)

Menus 84-87: Composite High Clip and Knee settings (PAL)

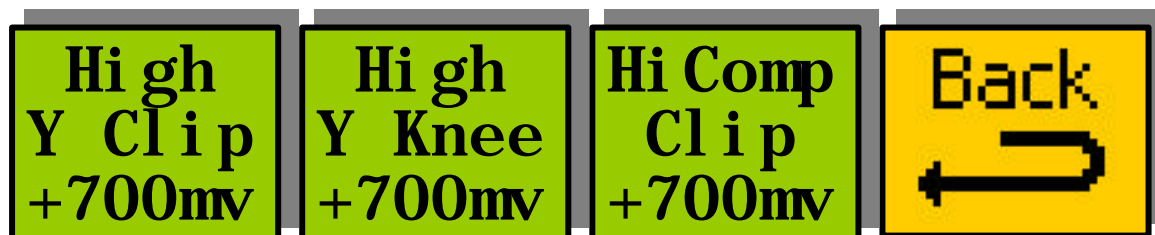

Menu Num.	Heading	Automation	Function
84	High Clip Level	[8-511]	This indicates the High Clip point for the Composite Y Clipping.
85	High Knee Level	[8-511]	This indicates the High Knee point for the Composite Y Clipping. This can be set to give a "soft clip" from this knee point to the hard clip point.
86	High Composite Clip Level	[8-511]	This indicates the High Clip point for the Composite Clipping.
87	BACK	none	Go to the Composite Clip and Knee menus (80-83)

Menu 88-91: Composite Low Clip and Knee Settings (PAL)

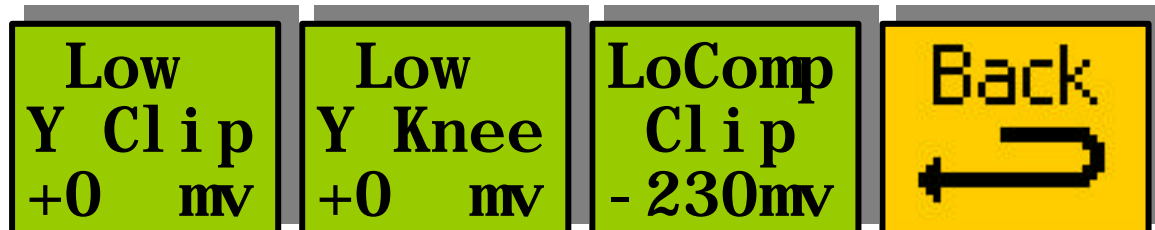

Menu Num.	Heading	Automation	Function
88	Low Clip Level	[8→511]	This indicates the Low Clip point for the Composite Luma Clipping.
89	Low Knee		This indicates the Low Knee point for

	Level	[8→511]	the Composite Luma Clipping. This can be set to give a “soft clip” from this knee point to the Low clip point.
90	Composite Low Clip Level	[8→511]	This indicates the Low Clip point for the Composite Clipping.
91	BACK	none	Go to the Composite Clip and Knee menus (80-83)

Menu 92-95: UTILITY MENUS - 1



Menu Num.	Heading	Automation	Function
92	LIFT/GAIN	none	Go to the Composite Clip and Knee menus (80-83)
93	Indicate	none	Go to the Composite Clip and Knee menus (80-83)
94	Ring Suppression	none	Go to the Composite Clip and Knee menus (80-83)
95	BACK	none	Go to the Setup menus (8-11)

Menu 96-99: UTILITY MENUS - 2



Menu Num.	Heading	Automation	Function
96	Log Errors	none	Go to the Log menu (128-131)
97	Miscellaneous	none	Go to the Miscellaneous menu (120-123)
98	Power On Memory and Reset	none	Go to the Power on Memory and Reset (132-135)
99	BACK	none	Go to the Setup menus (8-11)

Menu 100-103: LIFT/GAIN MENUS

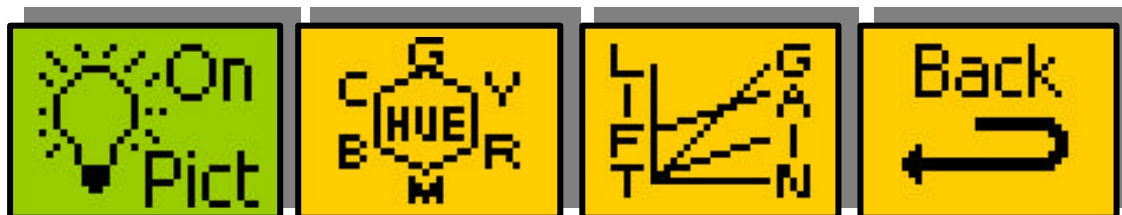

Menu Num.	Heading	Automation	Function
100	Lift, Gain, Hue and Black Control	On Off [0→1]	Active=Proc amp is processing, gain, hue and black controls are active Bypass= Unity Gain and no black offset.
101	HUE	none	Go To the Hue menus (104-107)
102	LIFT/GAIN	none	Go To the Luma, Chroma and Black menus (108-111)
103	BACK	none	Go to the Utility Menus - 1 (92-95)

Menus 104-107: Hue Control

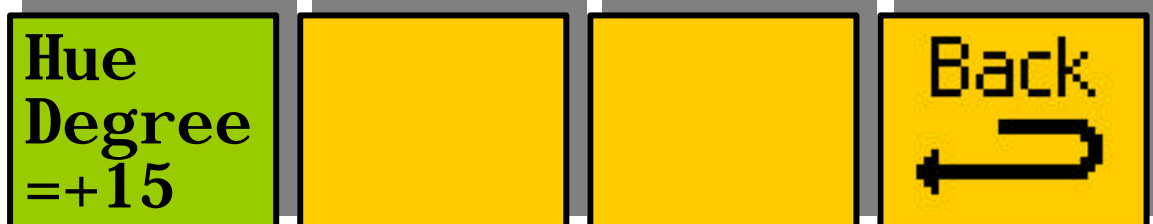

Menu Num.	Heading	Automation	Function
104	Hue	-180 to +180 degrees [-511 → +512]	Hue Rotation value, in degrees.
105		none	Blank
106		none	Blank
107	BACK	none	Go to the Lift/Gain menus (92-95)

Menus 108-111: Processing amplifier status.

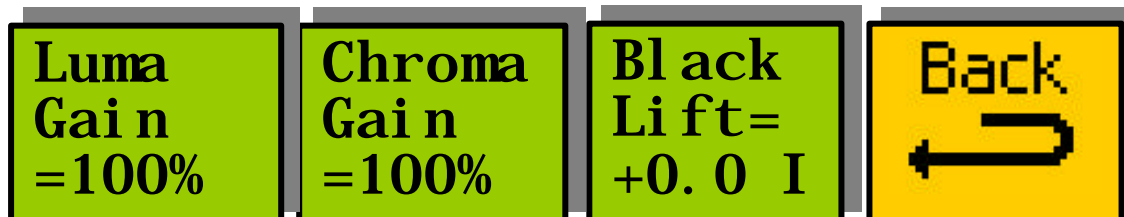

Menu Num.	Heading	Automation	Function
108	Luma Gain	0 → 200% [0 → 511]	Luminance Gain Adjustment
109	Chroma Gain	0 → 200% [0 → 511]	Chrominance Gain Adjustment
110	Black Level	+/- 20% Range [-255 → 255]	Black level adjustment
111	BACK	none	Go to the Lift/Gain menus (100-103)

Menu 112-115: Ring control menus

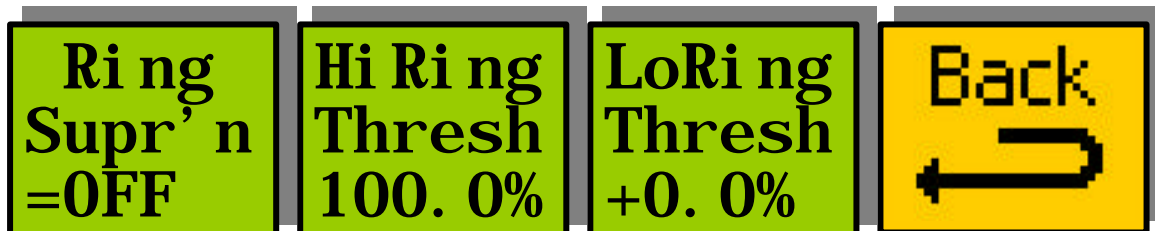

Menu Num.	Heading	Automation	Function
112	Ring Suppression Mode	Off Auto Manual [0→2]	Off= No overshoot or undershoot suppression is employed Auto= The Overshoot and Undershoot suppresser automatically tracks the Settings for the High and Low clip on the Legaliser section. Manual= The user can set the High and low Ring suppression thresholds manually.
113	High Ring Suppression Threshold	51% → 109% [512→1023]	When "Ring Suppression" Mode is in "Manual". This menu allows the user to set the upper limit at which no luma signal can go beyond, whether this is due to its absolute level, or its achievable level as an overshoot or undershoot on a 601 filter.
114	Low Ring Suppression Threshold	-8% → 50% [0→511]	When "Ring Suppression" Mode is in "Manual". This menu allows the user to set the lower limit at which no luma signal can go below, whether this is due to its absolute level, or its achievable level as an overshoot or undershoot on a 601 filter.
115	BACK	none	Go to the Utility Menus - 1 (92-95)

Menus 116-119: Out of Gamut Colour

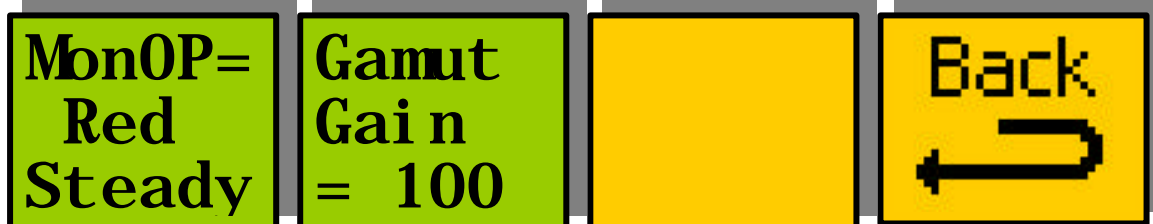

Menu Num.	Heading	Automation	Function
116	MonOP	RedSteady GreenSteady BlueSteady WhiteSteady LegalOut [0→4]	This is the colour used to indicate the areas of the picture currently being processed by the legaliser.
117	Gamut Gain	none	Controls the gain applied to the over/under shoot signal before it is used to key in the gamut indication colour
118		none	Blank
119	BACK	none	Go to the Utility - 1 menus (92-95)

Menus 120-123: Miscellaneous utility menus

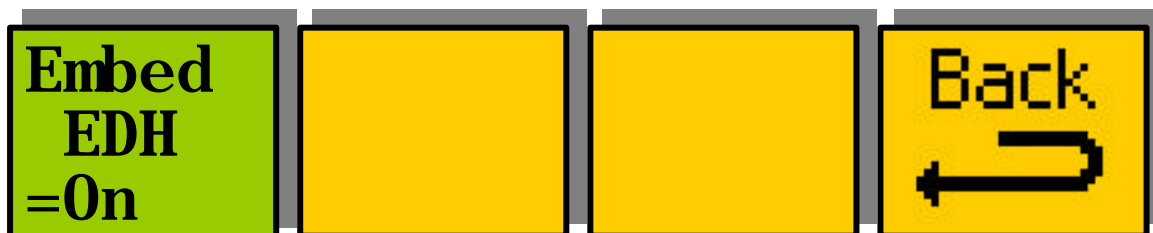

Menu Num.	Heading	Automation	Function
120	Embed EDH	Off On [0→1]	This will switch in and out the embedded EDH on the main output.
121		none	Blank
122		none	Blank
123	BACK	none	Go to the Utility Menus - 2 (96-99)

Menu 124-127: Software Version

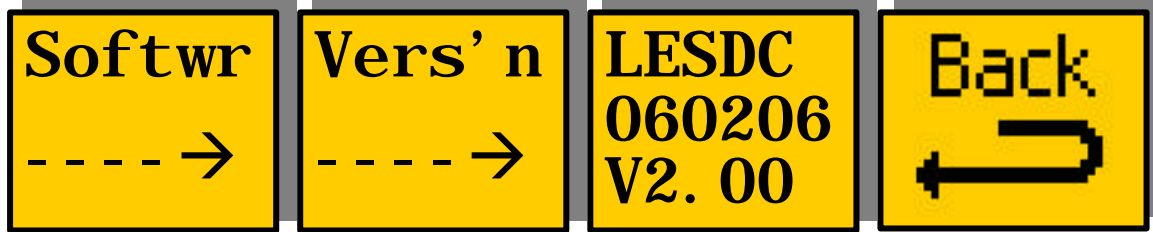

Menu Num.	Heading	Automation	Function
124		none	Blank
125		none	Blank
126	Software Version	N/A	Shows the current software version
127	BACK	none	Go to the Top Level Menus (0-3)

Menus 128-131: Log mode menus

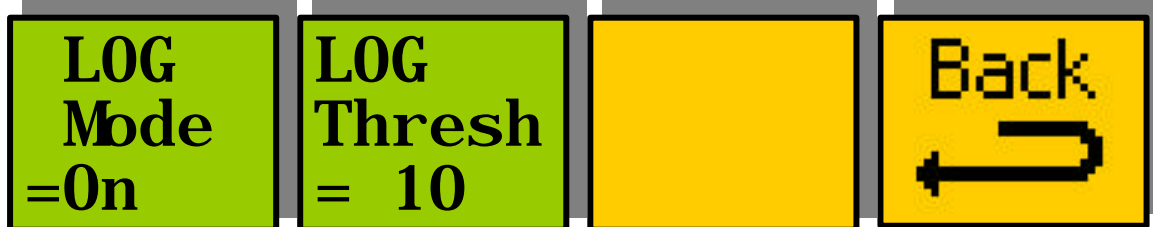

Menu Num.	Heading	Automation	Function
128	Log Mode	Off On [0→1]	This will switch on and off the Error Logging output on the RS232 port. This output can be used in conjunction with the Eyeheight TimeCode software to display the errors and timecodes so that problem sections can easily be located
129	Log Threshold	none	Specifies the absolute magnitude of allowable over/undershoot before the pixel is logged as severe in the PC logging application.

130		none	Blank
131	BACK	none	Go To the Utils menus (36-39)

Menu 132-135: Power-on & Reset Controls



Menu Num.	Heading	Automation	Function
132	Set As Pow On Memory	1=save	Pressing this will save the current set up as the power on default.
133	Recall Pow On Memory	1=Recall	Pressing this will recall the power on default settings.
134	TOTAL RESET	1=Reset	Pressing this will reset the system.
135	BACK	none	Go to the Utility Menus - 2 (96-99)

5 PC Logging Application

5.1.1 Installation

The latest version of the logging application can be downloaded from http://www.eyeheight.com/software_top.htm. The software requires the .NET Framework v1.1 to be installed on the PC to be used for logging. The .NET Framework can be downloaded free of charge from <http://www.microsoft.com>.

Extract all files in the LESDC_logger.zip file to a directory of your choice. Run the logger.exe file to start the logger.

5.1.2 Setting Up for Logging

For successful logging the unit needs to be set to generate the logging output by setting the “Log Mode” menu to on. The unit then needs to be connected to a spare COM port on the PC (make a note of the com port number as it will be required when configuring the logging software) using a standard serial cable. Finally the com port needs to be configured in the logging software via the Comms menu.

5.1.3 Understanding the Application

The application provides a graphical log of the percentage of pixels in the incoming video which are considered to be illegal and the GUI can be seen in Figure 12. The application also provides a visual indication of illegal(green) and severely illegal(red) pixels where a pixel is considered to be severely illegal if it is more illegal than the gamut threshold. This enables the operator to isolate the dangerously illegal cases from those caused by minor variations between legaliser designs.

To start logging set up the COM port in the comms menu and then click start. The logging operation can be suspended by hitting the stop button. Where timecode is available to the unit via VITC the application will log data against the timecode. If the timecode stops the log will also stop. If no timecode is present the application will log continually.

The received section gives details of the last log entry received whilst clicking on the graph window brings up the cursor and populates the cursor section with the log entry relating the selected bar. The zoom control allows viewing of a larger area of the log data.

Logs can be saved and opened at a later date using the file menu.

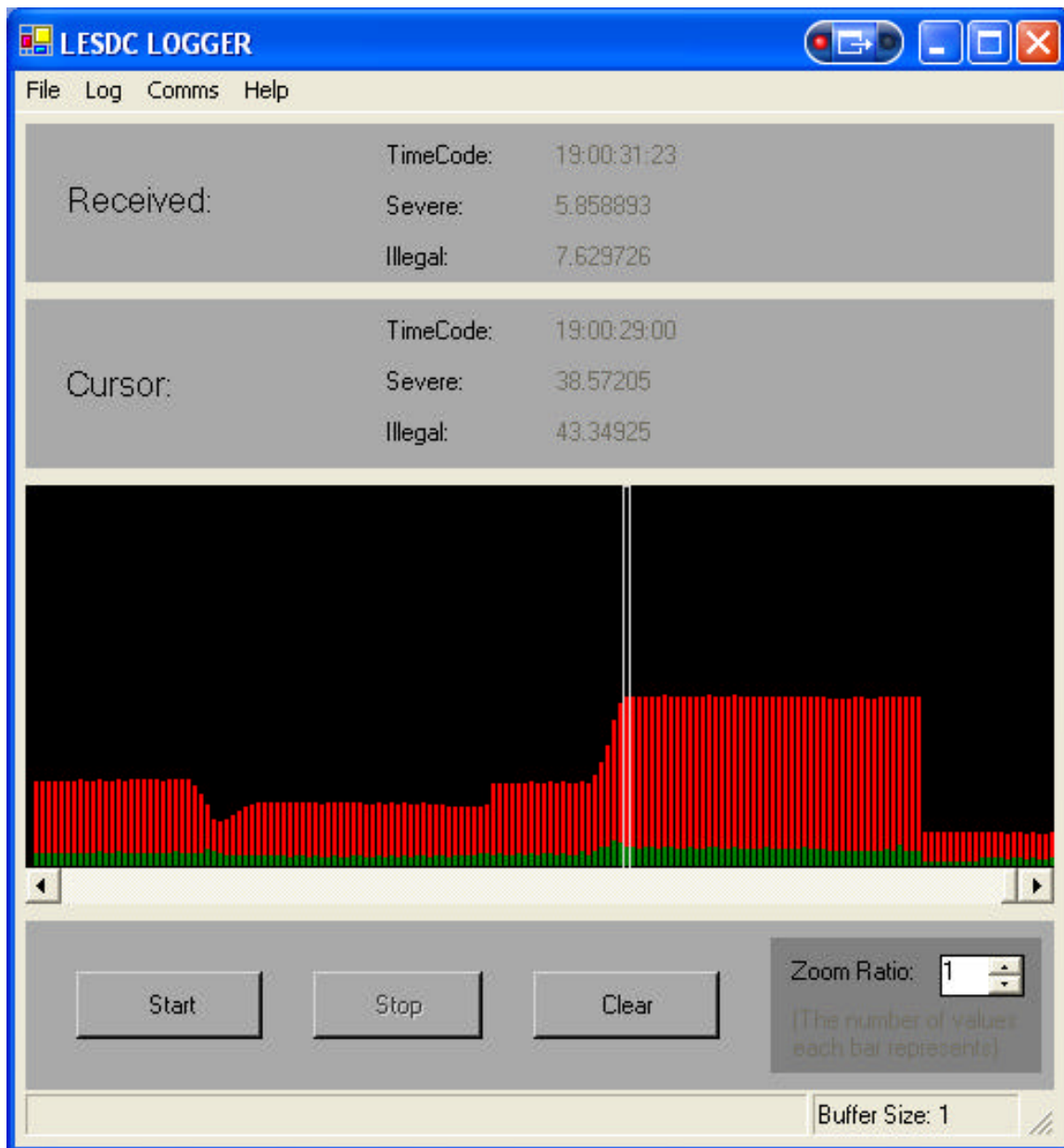

Figure 12 - Logging Application GUI