



eyeheight



BL-I/BL-ID

basic single and dual channel legaliser system.

user manual

Table of Contents

1 System overview	4
1.1 Applications for the BL-1	4
1.2 Technical overview of the BL-1	4
1.3 Memory operation on Single and Dual BL-1 Units	5
1.4 Associated Equipment for the BL-1	6
1.4.1 Chassis Types	6
1.4.2 Control Surfaces	6
2 Installation	8
2.1 Installation of the BL-1 product	8
2.2 Installing the BL-1 into a flexiBox	8
2.3 Connecting to an BL-1, BL-1D.	8
2.4 Connecting Panels to the BL-1	9
3 Operation	10
3.1 Manual control of the BL-1	10
3.2 Automation Control of the BL-1	10
3.3 Operational Menus for the BL-1D	10
4 Technical Appendix	16
4.1 Technical Specification for the BL-1D	16
4.2 Jumpering the I-BUS (CAN-BUS) Termination	16

Table of Figures

Figure 2-1 BL-1, BL-1D legaliser PCB.....	4
Figure 2-2 Sytem diagram of the BL-1 channel.....	5
Figure 2-3 FlexiBox with flexiPanel fitted.....	6
Figure 2-4 FP-10 desktop modular panel.....	6
Figure 2-5 FP-9 1RU panel.	7
Figure 2-1 BL-1/1D rear connections. (jumpers show default for the BL-1).....	9
Figure 4-1 Location Of I-Bus Termination Link.....	16

I System overview

The BL-1 is a basic Legaliser system. The correction is done in RGB colour space. The BL-1D is a dual channel version of the BL-1. This manual will refer to the BL-1 for the most part only indicating differences that are relevant for the dual channel BL-1D unit.

The main features of the BL-1 are as follows:

- Full legalisation to RGB colour space.
- Dual channel, cost effective version available on one card.
- Out of Gamut "Indicate" Mode
- 8 User Memories.
- Automation controllable

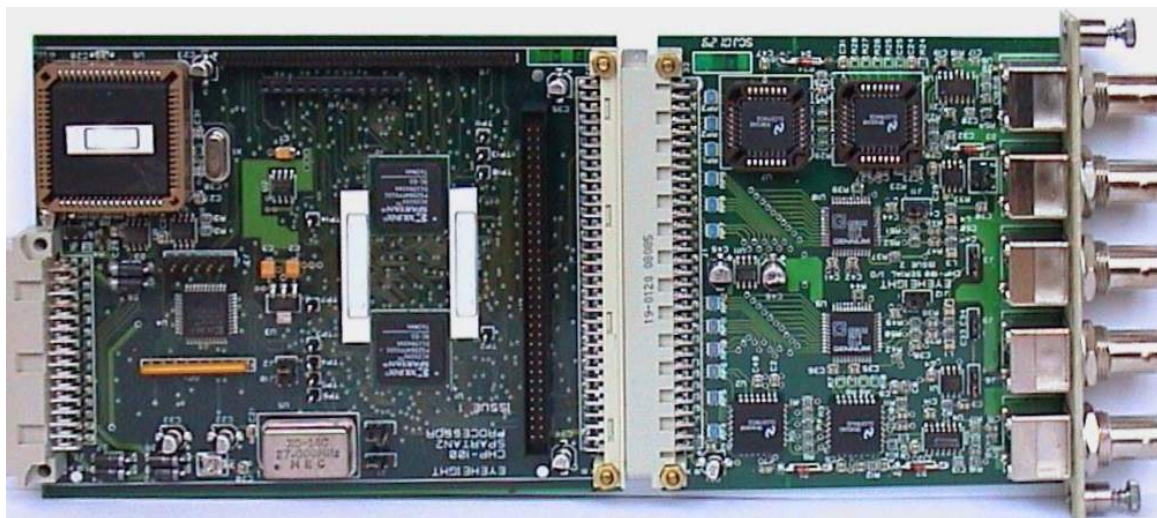

Figure 1-1 BL-1, BL-1D legaliser PCB.

I.1 Applications for the BL-1

Applications for the BL-1 include the following:

- Cost effective basic colour legalisation of multi channel transmission centres.
- Low cost answer to workstation legalisation. Reduces tape rejection by broadcasters.

I.2 Technical overview of the BL-1

The Legaliser consists of a colour space conversion from Y,Cr,Cb to R,G,B. This first conversion then enters the RGB Clip unit. This has three purposes:

To Clip, and therefore legalise the incoming signal.

To provide a signal that indicates that a particular part of the signal is legal or illegal ("Not in clip", or "In clip").

To provide information to a "Colour Field Generator" (Not shown) to show parts of the picture that is illegal on the SDI Output.

The Legaliser section has a switch that selects either the fully bypassed input signal or the "Clipped" or "Legalised" signal. Any signal that is within the specified RGB Legal parameters will pass through the unit transparently. When the unit senses that it is in an "Illegal" part of the signal, it will switch in its processing to output the Clipped (Modified) part of the signal. The Processed part of the signal is to a rounded 8 bit accuracy. This is acceptable because it is only the Clipped portion of the signal that will pass through the processing chain.

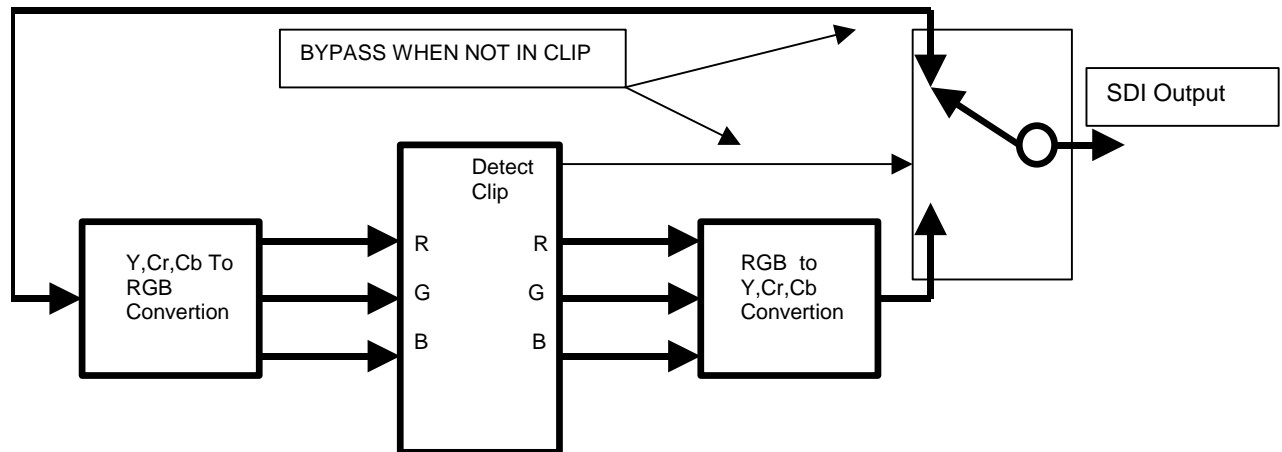

Figure 1-2 System diagram of the BL-1 channel.

I.3 Memory operation on Single and Dual BL-1 Units

A single BL-1 Unit has 8 memories. These memories both store the TOTAL set-up of the unit.

A dual unit has 8 memories. These Store all the settings for **BOTH** channels. The memories cannot be operated independently.

I.4 Associated Equipment for the BL-1

The BL-1 is a module and requires both a chassis and a control surface to function.

I.4.1 Chassis Types

- **flexiBox** is a 1RU chassis. The order code is FB-9. This will hold a maximum of 6 BL-1 Modules with “Hot Swap” redundant PSU option and “Hot Swap” BL-1 modules.
- **maxiBox** is an alternative low cost 1RU chassis. The order code is MX-9. This also will hold a maximum of 6 BL-1 modules but it has no redundant PSU option and the BL-1 units must be factory fitted.



Figure 1-3 FlexiBox with flexiPanel fitted

I.4.2 Control Surfaces

- **flexiPanel** is a 1RU control surface that fits on the Front of a 1RU flexiBox. The order code is FP-9. A FlexiPanel can also be used in conjunction with a miniBox, in this case the extra accessory (Order code RR-9) will be required
- **FP-10** is a desk mounting control surface (Order code FP-10). This unit is a modular unit which can be used in conjunction with the units below.



Figure 1-4 FP-10 desktop modular panel



Figure 1-5 FP-9 1RU panel.

2 Installation

2.1 Installation of the BL-I product

If this unit is already pre-installed in a flexiBox (FB-9), or a maxiBox, with either a local or a remote panel from the factory then refer to the "Hardware Installation Guide" which will be enclosed with the system. If this unit is pre-installed in a miniBox (MB-9), then also refer to the "Hardware Installation Guide" which will be enclosed with the system

If this unit has been ordered separately, we assume here that you already have a flexiBox system with a Flexipanel and that the flexiBox has at least one spare slot for the BL-1 card.

2.2 Installing the BL-I into a flexiBox

To install the BL-1 into a flexiBox it is desirable (but not necessary) to power down the flexiBox. Follow these instructions.

On the rear of the flexiBox are 6 slots for Products. Remove any spare blanking plate. There are 2 off M2.5 Screws, which require unfastening for each blanking plate.

Slide the Product PCB into the spare slot and firmly push it "home".

Use the two thumbscrews to fasten the unit in place.

Now refer to the "GeNETics User Guide". If your system consists of a single flexiBox with a single flexiPanel then refer to the section titled "flexiPanel Auto Set-up". If your system is part of a network with more than one flexiPanel then refer to the section titled "flexiPanel Manual Set-up". This will guide you through acquiring your product as a device on the flexiPanel.

2.3 Connecting to an BL-I, BL-ID.

The connections for the BL-1 are shown below. The BL-1 has only Channel 1 whilst the BL-1D has both channels. The BNC's are configurable with links on the I/O card. With the jumper links shown in their default positions, the following tables defines the connections for the BL-1D and the BL-1.

BNC, numbered from left to right.	Function of connection (BL-1D).
1	Channel 1 input
2	Channel 1 active loop
3	Channel 1 legal output
4	Channel 2 legal output
5	Channel 1 input

BNC, numbered from left to right.	Function of connection (BL-1).
1	Channel 1 input
2	Channel 1 active loop
3	Channel 1 legal output
4	Channel 1 legal output
5	Not Used

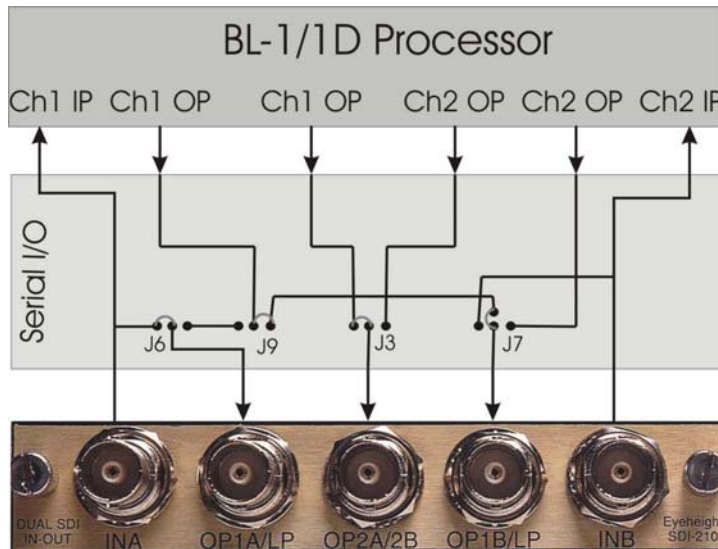

Figure 2-1 BL-1/1D rear connections. (jumpers show default for the BL-1)

2.4 Connecting Panels to the BL-1

The BL-1 may be operated using a FP-9 Flexipanel locally mounted. The BL-1 can be controlled from a remotely mounted FP-9 or FP-10. For detailed information on connecting remote panels refer to the section “Connection of Remote Panels to a flexiBox” in the geNETics Hardware Installation Guide.

3 Operation

3.1 Manual control of the BL-1

Manual Control of the BL-1 is done using one or more of the following control surfaces:

- The 1RU FP-9 Flexipanel.
- The FP10 Desk mounting Panel

The FP-9 and the FP-10 have identical manual control systems. (The FP-10 is simply a desktop version of the FP-9). The BL-1 is, as are all genetics modules, controlled using a set of MENUS. Each of these menus contains up to 3 parameters that are adjusted using the rotary digipots. The Menus define all of the adjustable operational parameters in the BL-1. Pressing the rotary digipots brings the parameter to its default value. Device selection is done using the device select switches which, when pressed, will offer the name of the device in the LCD Window. Modules can be acquired and then de-acquired using the set-up switch. For a full description of the operation philosophy of the geNETics system refer to the “geNETics User Guide” (section “Operation of the flexiPanel”)

A full list of the Menus and their functions are given in section 3 of this chapter.

3.2 Automation Control of the BL-1

Automation of the geNETics products is achieved via an RS422 port.** This port is marked RS422 on the rear of a flexiBox. For the port to work a flexiPanel MUST be connected locally on the front of the flexiBox.

Automation control of the BL-1 is possible using the geNETics automation protocol.

Genetics protocol is described in detail in the “GeNETics User Guide” section titled “Automation Protocol on the geNETics Platform”. The menu list in section 3 of this chapter contains the data information for the protocol.

**On most flexiBoxes later than 1/10/02 the RS422 port has been replaced by a “D-Bus” Port. The D-Bus port is for High Speed data transfer and is not used for serial control. In order to achieve serial control of any products on an I-Bus network Eyeheight Ltd have developed a RS232→I-bus converter “dongle”, (DG-9) which enables greater flexibility of products on the I-Bus network whilst using the same protocols as the RS422 port. Please refer to the “User guide for the DG-9 eyeheight dongle and set-up software.

3.3 Operational Menus for the BL-ID

Note that for the BL-1 menus 8→11 are missing. For automation purposes you will be required to subtract 4 from the menu number after menu 8 for programming the BL-1 to respond to automation commands.

Menus 00-03 Top Level Menus.

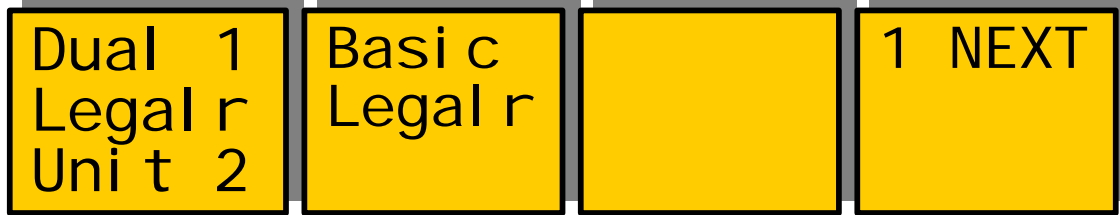

Menu Num.	Heading	Automation	Function
00	Title	none	
01	User Name	none	This can be programmed by the user. See genetics user guide.
02			
03	Next		This prompts the user to hit the next key for further menus.

Menus 04-07 Channel 1 set-up.

(Press "NEXT/PREV" to navigate)

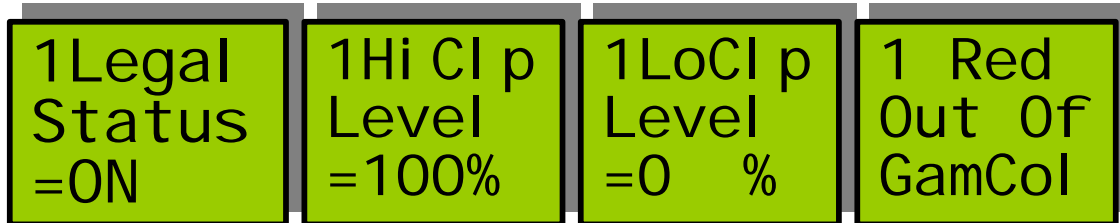

Menu Num.	Heading	Automation	Function
4	Legaliser Status. (chan1)	On Show Flash Off [0→3]	This shows the status of the Legaliser block only. (NOT the Proc amp (Input Gain) or the Overshoot suppression. <ul style="list-style-type: none"> • On=ON, Legaliser is active. • Show= Indicate Illegal parts of the picture with a fill-in colour. • Flash= Indicate Illegal parts of the picture with a fill-in Flashing colour. • Off=OFF, Legaliser is in Bypass.
5	High Clip Level (chan1)	51% → 109% [128→255]	This indicates the High Clip point for the RGB Clipping. This is normally set to 100% for clipping at 0.7V in the analogue domain.
6	Low Clip Level	-8% → 50% [0→127]	This indicates the Low Clip point for the RGB Clipping. This is normally

	(chan1)		set to 0% for clipping at 0V in the analogue domain.
7	Out of Gamut Colour (chan1)	Black Blue Red Purple Green Cyan Yellow White [0→7]	This is the colour used to fill in the illegal parts of the picture in "Show" or "Flash" indicate modes.

Menus 08-11 Channel 2 set-up.

(Press "NEXT/PREV" to navigate)

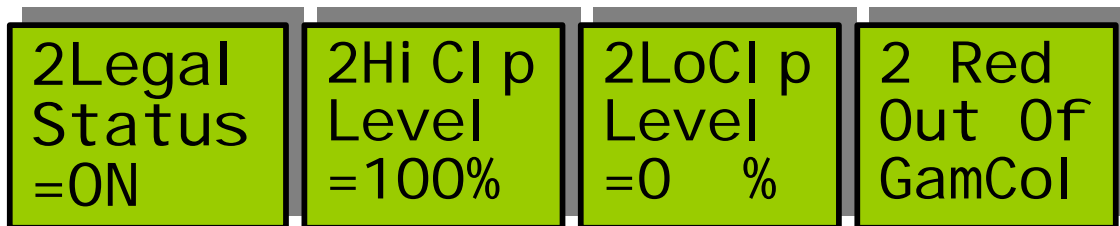

Menu Num.	Heading	Automation	Function
8	Legaliser Status. (chan2)	On Show Flash Off [0→3]	This shows the status of the Legaliser block only. (NOT the Proc amp (Input Gain) or the Overshoot suppression. <ul style="list-style-type: none"> • On=ON, Legaliser is active. • Show= Indicate Illegal parts of the picture with a fill-in colour. • Flash= Indicate Illegal parts of the picture with a fill-in Flashing colour. • Off=OFF, Legaliser is in Bypass.
9	High Clip Level (chan2)	51% → 109% [128→255]	This indicates the High Clip point for the RGB Clipping. This is normally set to 100% for clipping at 0.7V in the analogue domain.
10	Low Clip Level (chan2)	-8% → 50% [0→127]	This indicates the Low Clip point for the RGB Clipping. This is normally set to 0% for clipping at 0V in the analogue domain.
11	Out of Gamut Colour (chan2)	Black Blue Red Purple Green ^	This is the colour used to fill in the illegal parts of the picture in "Show" or "Flash" indicate modes.

		Cyan Yellow White [0→7]	
--	--	----------------------------------	--

Menu 12-15: Memory Controls

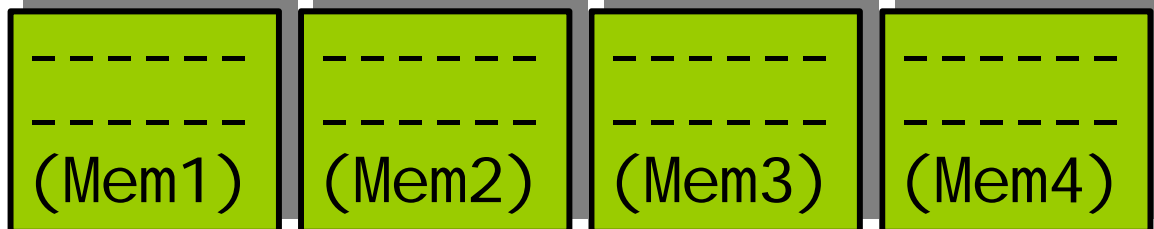

Menu Num.	Heading	Automation	Function
12	MEM1	1=Recall	Pressing this will recall Memory number 1. User Names can be programmed in to the memories using a keyboard. See "geNETics User guide", section "Giving product Memories names"
13	MEM2	1=Recall	Pressing this will recall Memory number 2.
14	MEM3	1=Recall	Pressing this will recall Memory number 3.
15	MEM4	1=Recall	Pressing this will recall Memory number 4.

Menu 16-19: Memory Controls

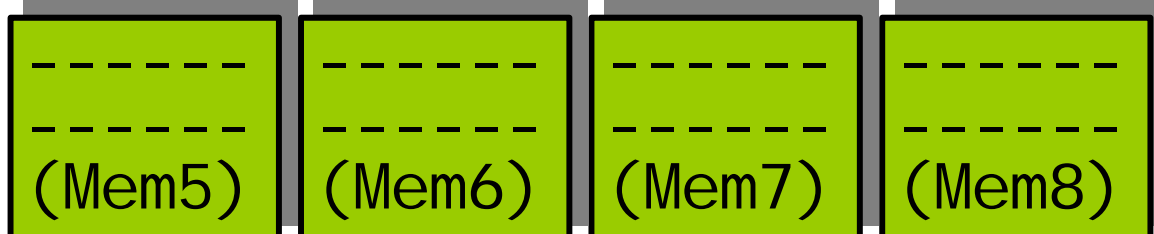

Menu Num.	Heading	Automation	Function
16	MEM5	1=Recall	Pressing this will recall Memory number 5.

			number 5.
17	MEM6	1=Recall	Pressing this will recall Memory number 6.
18	MEM7	1=Recall	Pressing this will recall Memory number 7.
19	MEM8	1=Recall	Pressing this will recall Memory number 8.

Menu 20-23: Memory Controls

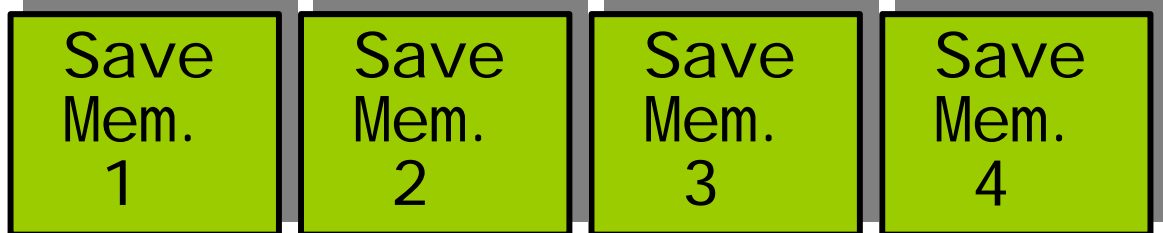

Menu Num.	Heading	Automation	Function
20	Save Mem. 1	1= Save	Pressing this will Save Memory number 1.
21	Save Mem. 2	1= Save	Pressing this will Save Memory number 2.
22	Save Mem. 3	1= Save	Pressing this will Save Memory number 3.
23	Save Mem. 4	1= Save	Pressing this will Save Memory number 4.

Menu 24-27: Memory Controls

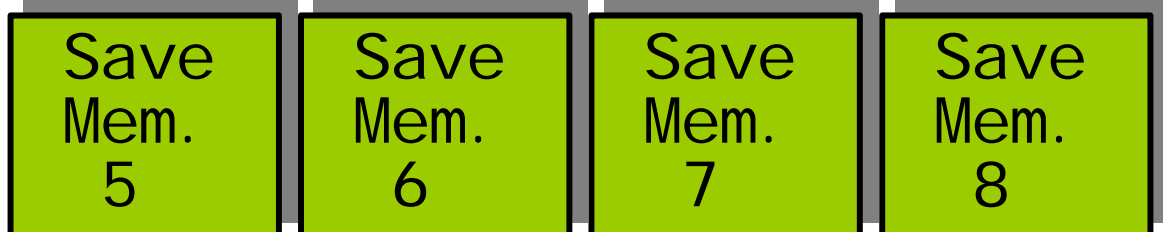

Menu Num.	Heading	Automation	Function

24	Save Mem. 5	1= Save	Pressing this will Save Memory number 5.
25	Save Mem. 6	1= Save	Pressing this will Save Memory number 6.
26	Save Mem. 7	1= Save	Pressing this will Save Memory number 7.
27	Save Mem. 8	1= Save	Pressing this will Save Memory number 8.

Menu 28-31: Top Level Controls



Menu Num.	Heading	Automation	Function
28	Set As Pow On Memory	1=save	Pressing this will save the current set up as the power on default.
29	Recall Pow On Memory	1=Recall	Pressing this will recall the power on default settings.
30	TOTAL RESET	1=Reset	Pressing this will reset the system.
31	Software Version	N/A	Shows the current software version.

4 Technical Appendix

4.1 Technical Specification for the BL-ID

Number of Inputs	2, SDI 270Mbit inputs
SDI Line Length	At least 200 Meters of PSF1/3 (Typically 275 Meters)
Number of Outputs	3, SDI 270Mbit inputs
SDI Output Jitter	The system will add less than 0.2UI to the input Jitter. (This is only guaranteed on issue 2 or later cards)
Current Consumption	<800mA at +5V
Size	215mm by 100mm

4.2 Jumpering the I-BUS (CAN-BUS) Termination

The I-BUS Network is the "control system" under which all Products and Panels are networked together. Under certain circumstances it is necessary to terminate the network. This can be done on a Panel or a "Product". To terminate this product, locate J6 on the BL-1 Processor Card supplied which is between U1 (The large square "chip") and the Edge connector. (This is on the half of the card labelled "CHP-100 Spartan2 Processor"). Jumper this with a 2mm link.

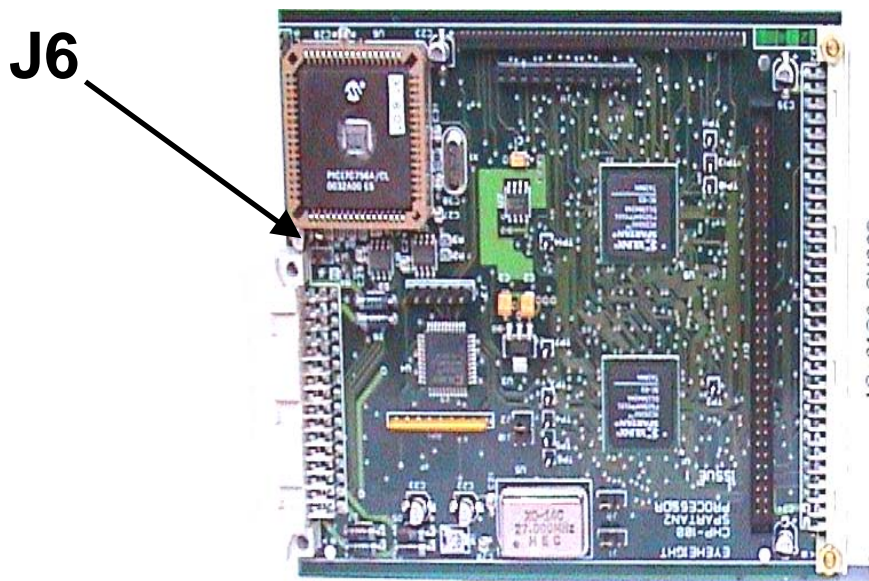

Figure 4-1 Location Of I-Bus Termination Link