



LK-2

Simple SDI Logo Inserter

user manual

User Manual Versions

Versions	Changes	Date	SW Vers
1.00	Version 7.2n New manual format (etherbox)	10/12/08	

Table of Contents

1 System Overview	6
1.1 The LK-2 Product.....	6
1.2 Associated Equipment for the LK-2.....	7
2 Installation	8
2.1 Connections on the LK-2 product.....	8
2.2 Connection to NetLogo.	8
2.3 The NetLogo application	9
3 Menu Control of the LK-2	11
3.1 Flexipanel controls.....	11
3.1.1 Device Buttons.....	11
3.1.2 Menu Navigation.....	11
3.1.3 Parameter adjustment of a green menu.....	12
3.1.4 Parameter adjustment of a red menu.....	12
3.1.5 Information display.....	12
3.2 Operation of LK-2.....	12
3.2.1 The play menus	12
3.2.2 Assigning names to a play	12
3.2.3 The EDIT Menus.....	12
3.2.4 Grabbing bugs	13
3.2.5 Preparing a bug for a play list	13
Memories	13
3.2.6 Power on memory.....	13
3.2.7 User Memories.....	14
3.2.8 Naming User Memories	14
3.3 Tamper Locking the LK-2.....	14
3.4 GPI/Tally Set-up.....	14
3.4.1 On-Board GPI's.....	14
3.4.2 On-Board Tally.....	15
3.5 Web Control of the LK-2	15
3.6 The LK-2 Menu Set.....	15
4 Technical Appendix.....	29

4.1	GPI/Tally/RS232 technical information.	29
4.1.1	GPI Inputs.....	29
4.1.2	Tally Output.	30
4.2	geNETics Automation Protocol Parameter table.....	30
4.3	Technical Specification.	33

Table of Figures

Figure 1 LK-2 Processing card.....	7
Figure 2 - Front view of etherbox (FB-9E) fitted with FF-9 blank panel	7
Figure 3 Rear view of etherbox with a single LK-2 installed.....	7
Figure 4 FP-9 Flexipanel can be fitted on the FB-9E or remotely using and RR-9 kit.	7
Figure 5 LK-2 connections	8
Figure 6 - Netlogo PC with Ethernet connection to etherbox.....	9
Figure 7 NetLogo application	10
Figure 8 Flexipanel (FP-9) controls.....	11
Figure 9 Types of menus showing their characteristic colours	11
Figure 10 Web Based control of the LK-2	15
Figure 11 Typical GPI Input.....	29

I System Overview

The LK-2 is a cost effective single channel bug inserter.

This manual must be used in conjunction with the etherbox manual which contains much of the generic information common to all eyeheight geNETics products.

I.1 The LK-2 Product

The LK-2 is a single channel logo inserter. The system will accept 270Mbit SMPTE 259 signals. This system enables up to 6 channels of logo insertion in a 1RU chassis. This LK-2 is designed to work in conjunction with the etherbox chassis (FB-9E) with NetLogo PC management software for logo set up and download to the LK-2. The system can work without NetLogo if the user is prepared to load logos from the SDI Input. In this case the older FB-9 chassis or MB-9 chassis can be used. The latter chassis have no connectivity with NetLogo.

The main features are :-

- The system will store up to 8 user defined “still” bugs.
- Internal keyer with bug fade facility.
- Real time “grab” of bug using SDI input possible.
- Compatible with NetLogo software if installed in the FB-9E etherbox.
- Safe area generator while in edit mode to help in bug positioning.
- Automation control.
- 8 On-board GPI's. (7 dedicated to logo's 1→7 and 1 for fade OFF.)
- On-Air tally relay closure.
- 6 User memories store all user settings.
- Compatible with etherbox GPI's.
- Mechanical relay bypass option available.
- Web Based Control Panel available.

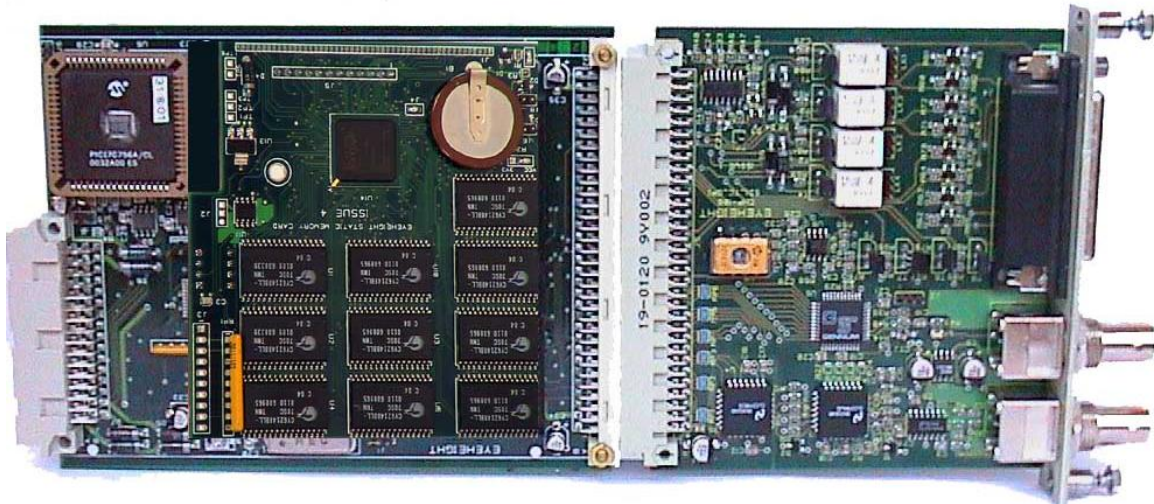

Figure 1 LK-2 Processing card.

I.2 Associated Equipment for the LK-2

The LK-2 processing card requires the following in order to set up and operate the unit.

1. An etherbox chassis (FB-9E). Up to six LK-2 units and be installed in one chassis. (An FB-9 or MX-9 can be used without NetLogo)
2. A Flexipanel control surface such as an FP-9 or an FP-10.



Figure 2 - Front view of etherbox (FB-9E) fitted with FF-9 blank panel

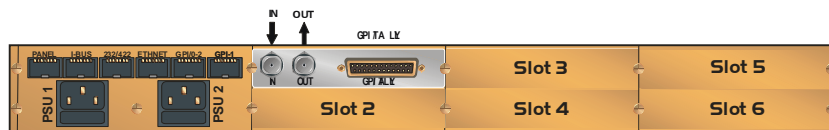

Figure 3 Rear view of etherbox with a single LK-2 installed.



Figure 4 FP-9 Flexipanel can be fitted on the FB-9E or remotely using and RR-9 kit.

2 Installation

This unit requires SDI digital video connections to the BNC connectors. Optionally GPI's and a Tally may also be connected normally using CAT5e cable. The user should refer to the etherbox user manual for installation of the LK-2 into a chassis and connection of flexipanel. This will also describe the process of acquiring a processing card (in this case the LK-2) by the Flexipanel which is necessary to access the menu structure within the LK-2.

2.1 Connections on the LK-2 product

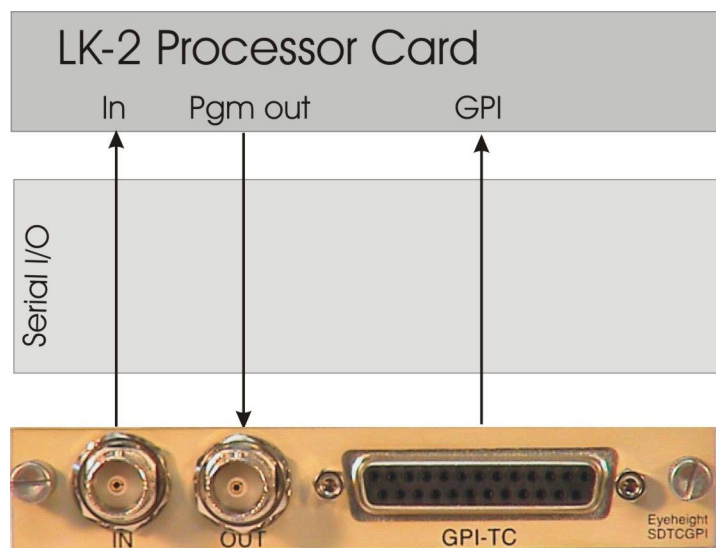

Figure 5 LK-2 connections

The main video connections to the LK-2 are shown above. The GPI/TALLY connection pin-outs are shown in the technical appendix at the end of this manual.

2.2 Connection to NetLogo.

The LK-2 is designed to work with the NetLogo PC Microsoft Windows application. The minimum PC requirement is a 1GHz processor with 256Mbyte memory and a 10/100 base T Ethernet port. The system should be running NT or XP professional operating system.

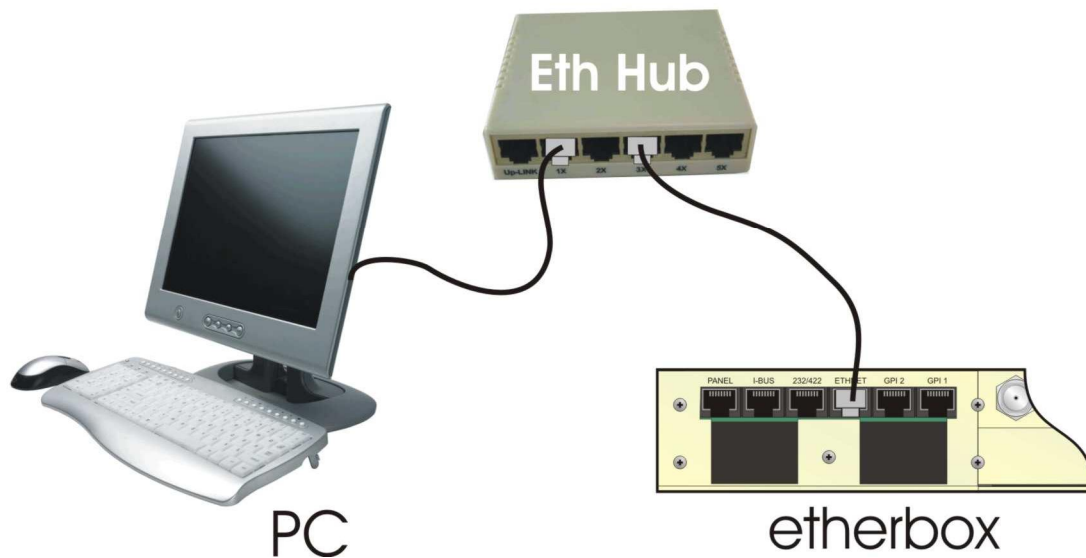

Figure 6 - NetLogo PC with Ethernet connection to etherbox.

The NetLogo application runs on the PC and requires a standard Ethernet connection to the etherbox. The user should refer to the etherbox manual for information regarding setting up the TCP/IP address for the etherbox.

2.3 The NetLogo application

The NetLogo application will allow the user to import 32 bit Targa files. These file types are chosen because they have an imbedded alpha channel which is required for logo creation. The Netlogo application allows the user to import Targa files which are then positioned and converted to the format required for logo download. The user can import multiple logos to make a play list. Finally the logos are downloaded into the LK-2 using the Ethernet connection. Once a set of logo's is downloaded they are semi-permanently stored in Battery backed memory within the LK-2.

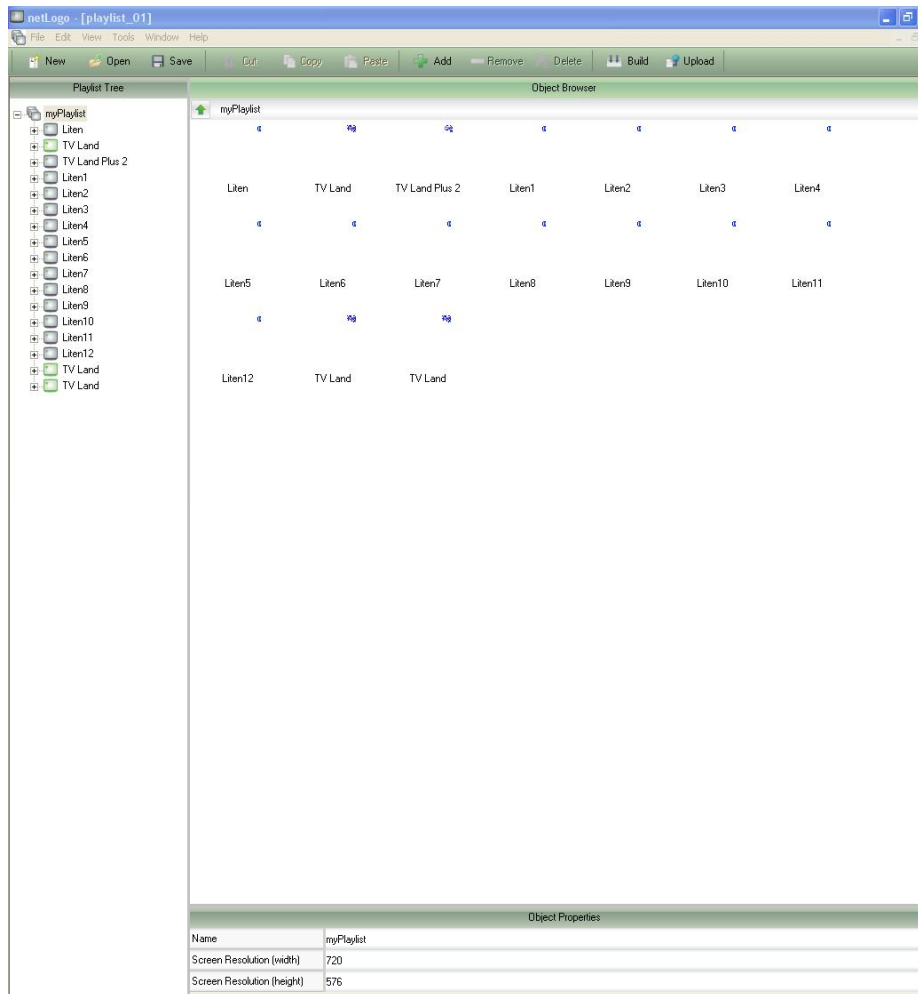

Figure 7 NetLogo application

NetLogo has a built in help system which will guide you through the process of importing logos, making play lists, configuring your LK-2 logo inserters and then downloading them into the LK-2 units.

3 Menu Control of the LK-2

All GeNETics products are controlled using a generic menu system. This generic menu system is operated from a generic panel (Flexipanel FP-9 or FP-10). An FP-9 is shown below (An FP-10 has the same controls in a different layout style). For information about acquiring processor cards for control on a Flexipanel see the etherbox manual section 4.

3.1 Flexipanel controls.

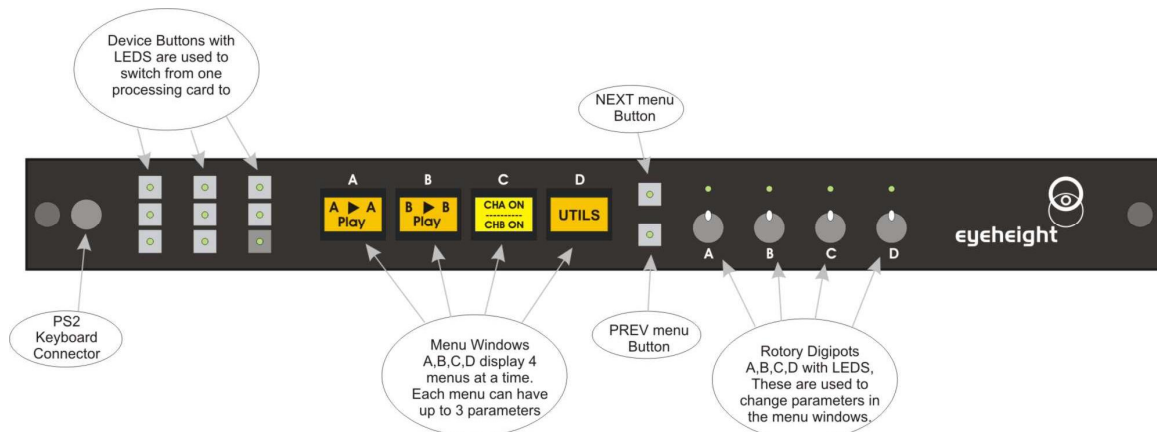

Figure 8 Flexipanel (FP-9) controls.

3.1.1 Device Buttons.

There are 8 grey device buttons. These switch between the currently selected processing cards installed in the etherbox. It is also possible to select cards in another chassis if the I-Bus is connected to the other chassis.

3.1.2 Menu Navigation.

There are two ways to navigate from menu to menu.

1. Using the NEXT and PREV buttons. These are for “Flat” menu structures. The NEXT and PREV LEDs will flash while further menus are available.
2. Using a **GOTO ANOTHER MENU** LCD button (as below coloured orange). This is more common and will take you straight to a relevant set of menus. Examples are the **Play** and **UTILS** menu’s shown on Figure 8.



Figure 9 Types of menus showing their characteristic colours

3.1.3 Parameter adjustment of a green menu.

A green menu is one in which there is only one adjustable parameter. There are two ways to adjust the parameter in a green menu.

1. Press the green LCD button. This will increment the value in that window. This is most frequently done when the menu parameter is Textural for example switching a parameter between ON and OFF. In this case a button press is most natural.
2. Use the Rotary digipot (A,B,C or D) to adjust the parameter in the respective LCD window (A,B,C or D). The direction and speed of rotation enable numeric values to be set easily.

3.1.4 Parameter adjustment of a red menu

A red menu is one in which there is two or three adjustable parameters. In this case it is necessary to first select the menu by pressing the red button. When the red button is pressed it will turn green and either two or three of the rotary digipot LEDs will flash indicating that the respective rotary digipot will operate the respective parameter.

3.1.5 Information display

A Yellow menu (Which on most panels does look a light orange!) is one in which only information is displayed. An example of this is the software version display.

3.2 Operation of LK-2

3.2.1 The play menus

The Top Level menu takes you into 4 distinct areas of the LK-2. The PLAY menus are where the user actually take a Bug to "air" and selects the next bug to "air. Only "PLAYS" can be taken to air. A "PLAY" is a bug that has been edited by the user using the EDIT menus and then Added to the Play List, or just downloaded using NetLogo "PLAYS" can also be given names of up to 12 characters.

3.2.2 Assigning names to a play

Names are assigned by the user to a PLAY while play menu 05 is displayed. Using an Eyeheight KB-9 keyboard connected to the FB-9/10 the user types "ENTER" and then can type a 12-character name. To exit the text editor type "ENTER" again. Each PLAY has a default name of "NewPlyNoName" (New play with no name assigned).

3.2.3 The EDIT Menus

The EDIT menus are used for capturing Bugs and then manipulating them and adding them to the play list. Once an edited bug has been added to the play list it

cannot then be changed in any way. These menus also enable the user to delete bugs and delete plays so providing a simple but effective bug management system.

3.2.4 Grabbing bugs

Bugs are grabbed from the SDI input of the LK-2 unit. Bugs must be prepared offline by a graphic system and then presented SDI to the input of the LK-2. In preparing a bug the artist must consider the “fill” (The bug picture) and the “key”. The brightness of the key signal at any point determines the opacity of the final overlaid bug.

The sequence for grabbing bugs is as follows, from top menu:

- EDIT→EDIT→ACQUIRE NEW BUG→ (LEFT RIGHT TOP BOTTOM)
- Set up the cursors in menus 36→39 to the required grab area. They will be seen on-screen.
- Press NEXT (Grey button)
- Press “GRAB” (menu 42). The system will say “VIDEO READY”
- Present the fill to the Scan Input of the LK-2 and press again. After a time the unit will say “KEY READY”
- Present the key to the Scan Input of the LK-2 and press again.
- Optionally name the bug. Please refer to section 3.2.2 except, this time, using this menu.

The system will now return to menus 12→15 in the EDIT menu where the user can start preparing the grabbed bug for the PLAY list.

3.2.5 Preparing a bug for a play list

The following is a typical sequence used to prepare a bug for a play list.

(if the user needs to get here from the top menu rather than using the section 3.2.4 sequence, then press EDIT→EDIT→NEXT (grey button))

- Use the H-POS_n and the V-POS_n menus (menus#13,14) to position the bug to the required position. The bug will move on-screen.
- Go directly to menu 21 by pressing NEXT→NEXT →(Add to play list) (Grey button) to add this to the play list.

Memories

3.2.6 Power on memory

On power up, this product will remember the logo selected and the logo state that has been saved in the Power-On memory. Other parameters such as fade transition times and GPI settings will follow the power on memory settings set as on menu 95.

3.2.7 User Memories

The user memories are a generic feature of all eyeheight geNETics products. Six of these are included in the LK-2. Parameters as shown in the **RED** menu numbers are saved. The user memories will also recall the current logo number and on-air state when they were saved.

3.2.8 Naming User Memories

The user memories can be named with up to 6 characters. To do this plug in a PS-2 Keyboard into a Flexipanel and select the appropriate processor card with a device button. (See Figure 9 for connector location). To name memory 1, "TXroom"

1. Hit F9 function key. The LCD displays will change to text entry mode
2. Type "M01:TXroom" and then press enter.
3. You may get a "not acknowledged" message, this does not matter.

Other memories can be named in the same way but changing the 01 to another memory number.

3.3 Tamper Locking the LK-2.

The user can lock specific menus or all the menus on the LK-2 so that it cannot be adjusted with a manual control panel. This does not effect automation.

To do this plug in a PS-2 Keyboard into a Flexipanel and select the appropriate processor card with a device button. (See Figure 9 for connector location). To lock only menu 5. (Next Logo for channel A)

1. Hit F9 function key. The LCD displays will change to text entry mode
2. Type "L05:" and then press enter.

A padlock symbol will appear on the menu and it cannot be adjusted. To unlock menu 5, type "A05:" as step 2 above. Other menus are done in the same way

To lock the whole product type "L:" as step 2 above and to unlock the whole product type "A:" as step 2 above.

3.4 GPI/Tally Set-up.

3.4.1 On-Board GPI's

The LK-2 has a GPI enable/disable menus. This is menu number XX

Unlike the BB-2 and BA-2 bug inserters the LK-2 includes a GPI interface which enables simple taking of bugs to "Air" in accordance with the GPI wiring in table in the appendix at the end of this manual.

3.4.2 On-Board Tally

The single tally output is an isolated relay closure.

3.5 Web Control of the LK-2

If the LK-2 is installed in the etherbox it is possible to control the LK-2 primary functions from a web based java applet. Please refer to the etherbox manual for instructions on how to set up the system to do this.

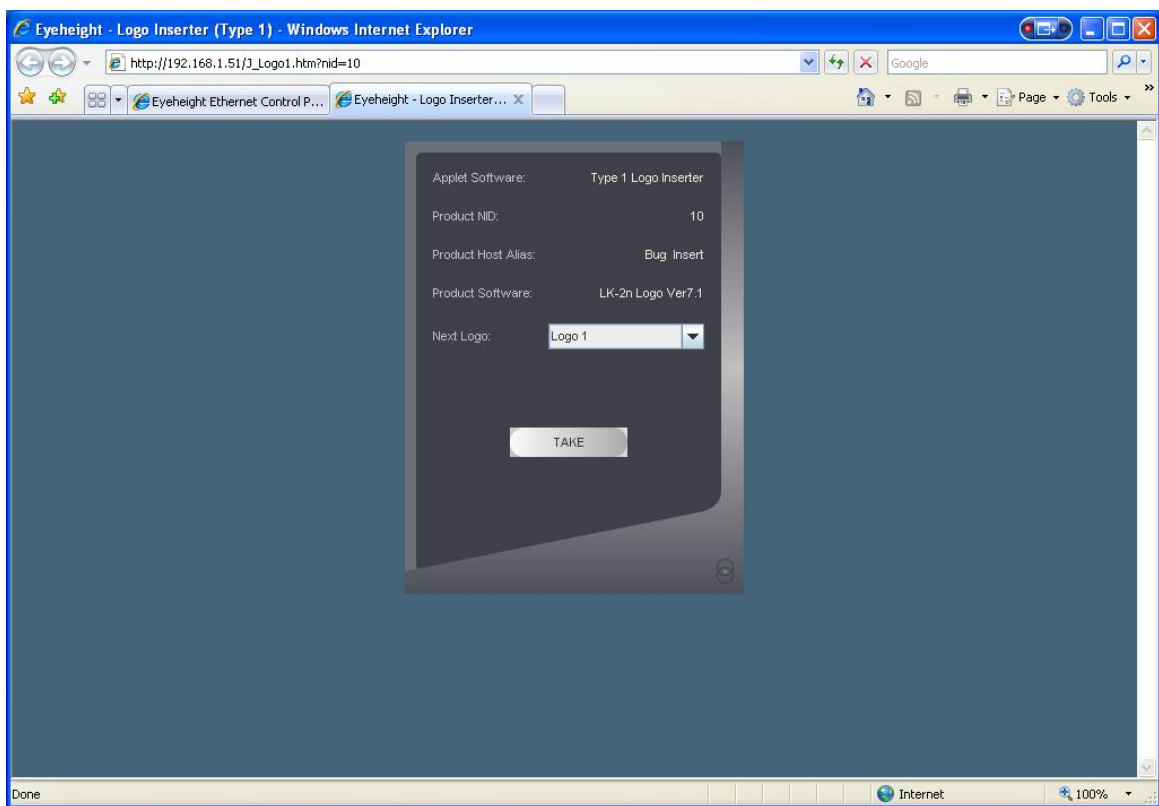

Figure 10 Web Based control of the LK-2

3.6 The LK-2 Menu Set.

The following set of menus defines the operational controls of the LK-2.

Note: Only parameters with **RED** menu numbers are stored in the memories and the Power-ON memory.

Menus 00-03 Top Level Menus

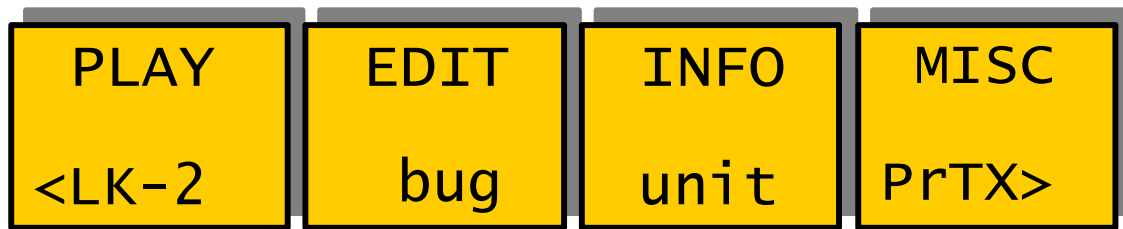

Menu Num.	Heading	Automation	Function
00	PLAY	none	Go To the main Play menu 4
01	EDIT	none	Go To the edit menu 8
02	INFO	none	This will Display the Software version
03	MISC	none	Go To the main miscellaneous menu 56

Menus 04-07 PLAY Menus

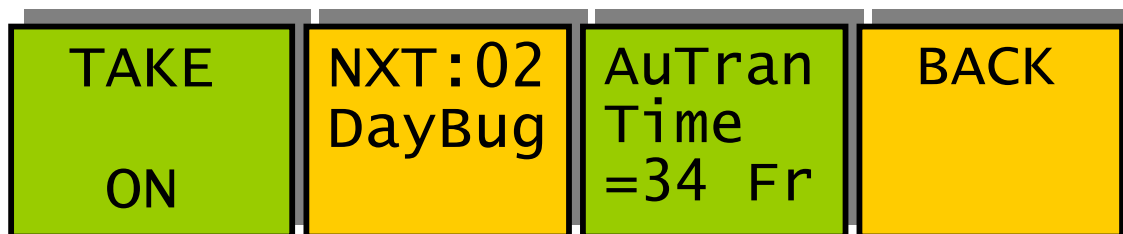

Menu Num.	Heading	Automation	Function
04	TAKE	[2=Fade Up 1=Fade Down]	Pressing this key causes a Fade Up/Down of the "Next Bug Play" shown in menu#5.
05	Next Bug	[1→nn]	The user selects here which "Bug Play" is called up next to Program. This may be changed while the previous bug is faded up and viewed on the Preview Output. The program output does not take this bug until the current bug is faded down and the next fade up transition is performed.
06	Auto transition time	0→5Secs [1→200]	This determines the time taken to make a transition on the program output. (Bug fades up or down). The readout is in seconds.
07	BACK	none	Go To the Top Level Menus

Menus 08-11 Edit menu tree

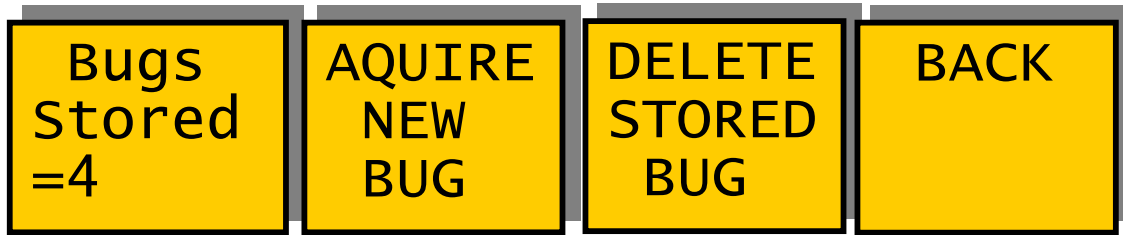

Menu Num.	Heading	Automation	Function
08	Bugs stored	none	This indicates to the user the number of Bugs in the Bug Store.
09	Acquire new bug	none	This takes the user to menus#36→43. It is using these menus, that the user grabs new bugs into the system.
10	Delete stored bug	none	This takes the user to menus#36→43. It is using these menus that the user grabs new bugs into the system.
11	BACK	none	Go To the Top Level Menus

Menus 12-15 Edit menu, bug positioning (NEXT to navigate)

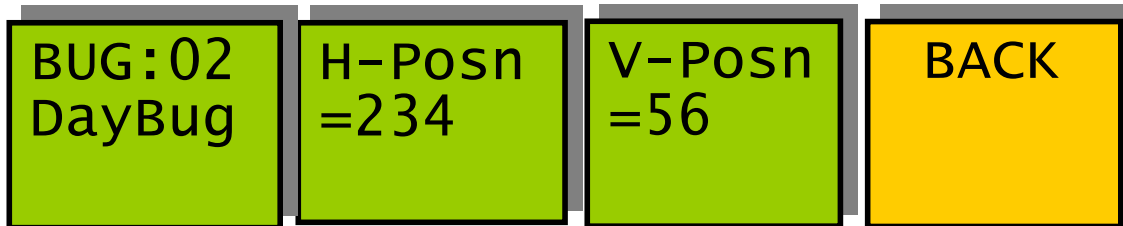

Menu Num.	Heading	Automation	Function
12	BUG:nn {Bug User Name}	[1→nn]	This selects the current Bug for editing into the “Bug Play List”. The user can move this bug into position and alter its animation parameters if applicable before adding it to the “Bug Play List”. The bug will be displayed on the preview output.
13	H-Posn <xxxx>	[0→719]	This will move the Bug selected in menu 12 horizontally.
14	V-Posn <xxxx>	[0→575] [0→488 for 525 sysms]	This will move the Bug selected in menu 12 vertically.
15	<BACK>	None	This Returns to the top menu#0→3 .

Menus 16-20 Edit menu, animation trimming (NEXT/PREV to navigate)

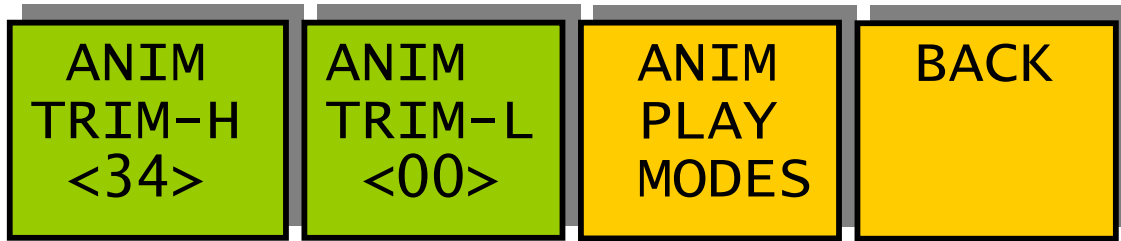

Menu Num.	Heading	Automation	Function
16	ANIM TRIM-H	[0→number of frames in animation-1]	BA-2 functionality ONLY – NOT LK-2
17	ANIM TRIM-L	[0→number of frames in animation-1]	BA-2 functionality ONLY – NOT LK-2
18	ANIM PLAY MODES	None	BA-2 functionality ONLY – NOT LK-2
19	<BACK>	None	This Returns to the top menu#0→3 .

Menus 20-23 Edit menu, play list management (PREV to navigate)



Menu Num.	Heading	Automation	Function
20	START ANIM'n	[0→1] Write a 1 for Take	BA-2 functionality ONLY – NOT LK-2
21	ADD TO PLAY LIST	None	This takes the user to menus#24→27. Once the Bug shown on the preview monitor has been set up as the user requires it can then be added to the “Bug Play List” by pressing this button.
22	DELETE PLAY ITEM	None	This takes the user to menus#28→31. This will delete an item in the “Bug Play List” if it is no longer required.
23	<BACK>	None	This Returns to the top menu#0→3 .

Menus 24-27 Confirm add to play list menus

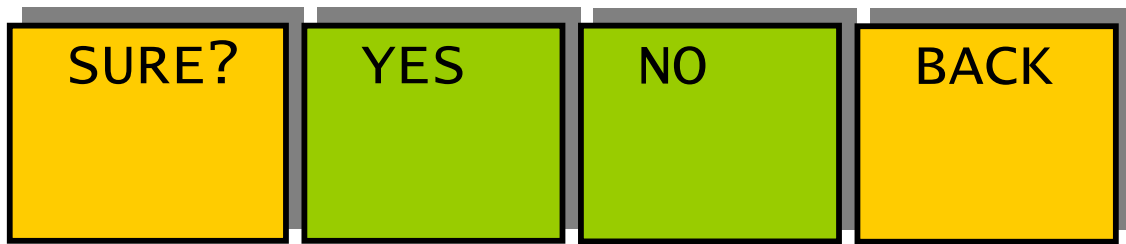

Menu Num.	Heading	Automation	Function
24	Sure?	None	Info
25	YES	[0→1] write a "1" to take.	This Accepts the "ADD TO PLAY LIST" Request.
26	NO	[0→1] write a "1" to take.	This Declines the "ADD TO PLAY LIST" Request.
27	<BACK>	None	This Returns to menus#20→23.

Menus 28-31 Play delete menus

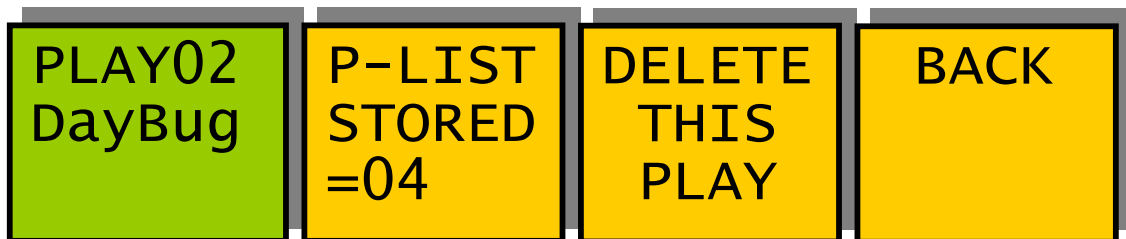

Menu Num.	Heading	Automation	Function
28	PLAYnn {Bug Play User Name}	[1→nn]	This selects the "Bug Play" that the user wishes to delete.
29	P-LIST STORED =nn	None	This shows the user the current number of "Bug Plays" in the "Bug Play List". Max 64.
30	DELETE THIS PLAY	[0→1] write a "1" to take.	This will perform the deletion of the "Bug Play" shown in menu number 28.
31	<BACK>	None	This Returns to menus#20→23.

Menus 32-35 Confirm delete play menus

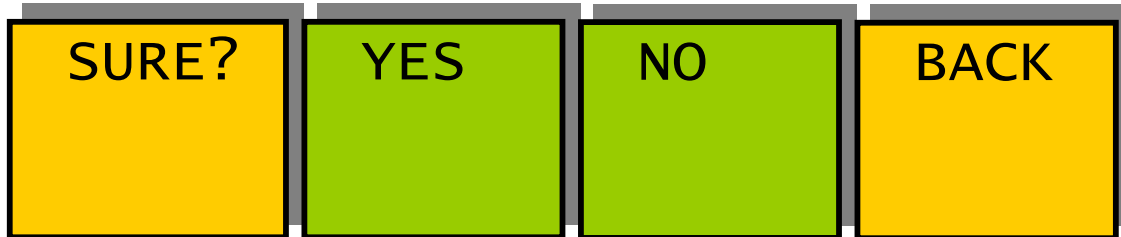

Menu Num.	Heading	Automation	Function
32	Sure?	None	Info
33	YES	[0→1] write a "1" to take.	This Accepts the "DELETE PLAY ITEM" Request.
34	NO	None	This Declines the "DELETE PLAY ITEM" Request.
35	<BACK>	None	This Returns to menus#20→23.

Menus 36-39 Grab cursor control (NEXT to navigate)

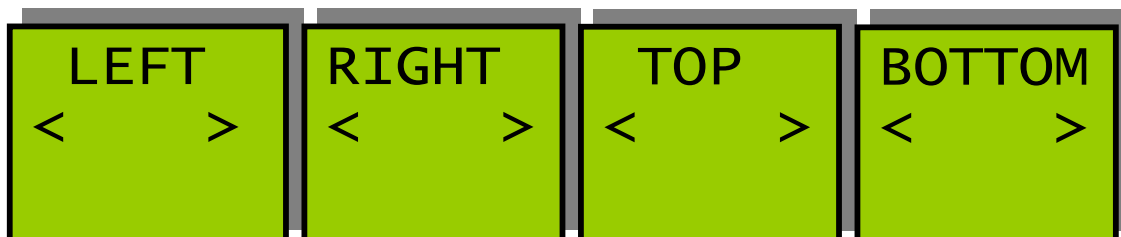

Menu Num.	Heading	Automation	Function
36	LEFT <XXXX>	[0→719]	On entering these menus a cursor "Box" appears and the Preview monitor switches to the "Grab" input of the unit. It is within this area that the Bug will be captured from the "Grab input". This Menu adjusts the left hand cursor.
37	RIGHT <XXXX>	[0→719]	Refer to above. This Menu adjusts the right hand cursor.
38	TOP <XXXX>	[0→576] 488 for 525 Systems	Refer to above. This Menu adjusts the Top cursor.
39	BOTTOM <XXXX>	[0→576] 488 for 525 Systems	Refer to above. This Menu adjusts the Bottom cursor.

Menus 40-43 Grab logo menus (PREV to navigate)



Menu Num.	Heading	Automation	Function
40	Num.Of Frames =nn	[0→255]	This selects the number of Video frames that the user wishes to Grab. For a “Still Frame” set this to “1”. For an animation, select the number of frames in the animation.
41	AQUIRE MODE <mode>	None	This displays the “Grab Mode” this will be “normal” for a still frame and “cue-dot” for animation.
42	!GRAB! !!!!!!!!!!!!!!	[0=OFF 2=Grab Vid 5=Grab Key]	<p>This menu takes the user through the Bug Grab Process.</p> <p>Hit Once: “Video Ready” Mode. The user must get ready the Bug Fill.</p> <p>Hit Again:[Grabs Video Input]</p> <p>The user must now get ready the bug key.</p> <p>Hit again:[Grabs Key Input].</p> <p>The user is required to Provide a video (Fill) and a key signal consecutively. If an animation is being grabbed the user must provide a frame with a “cue-dot” on the frame prior to the actual Bug animation and the Bug animation Key.</p>
43	<BACK>	None	This Returns to menus#8→23.

Menus 44-47 Delete bug menus

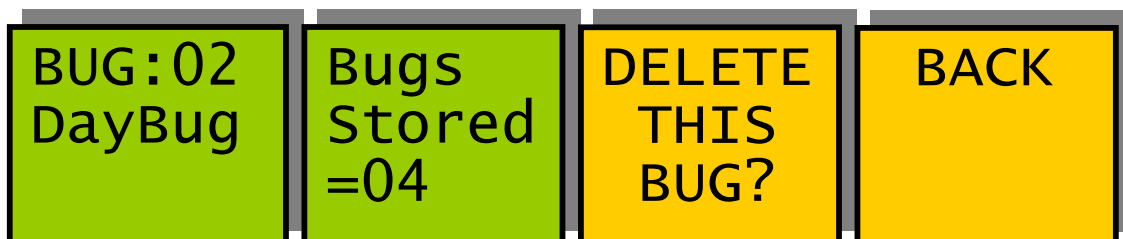

Menu Num.	Heading	Automation	Function
44	BUG:nn {Bug User Name}	[1→nn]	This selects the "Bug" that the user wishes to delete.
45	BUGS STORED =nn	None	This shows the user the current number of "Bugs" in the "Bug Store". Max 64.
46	DELETE THIS BUG	[0→1] write a "1" to take.	This will perform the deletion of the "Bug" shown in menu number 44.
47	<BACK>	None	This Returns to menus#8→23.

Menus 48-51 Confirm bug delete menus

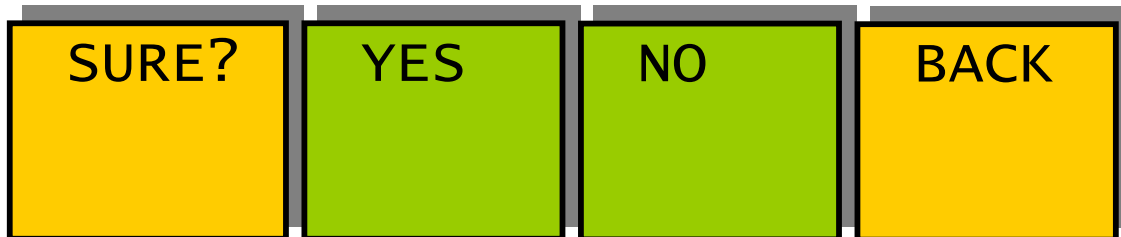

Menu Num.	Heading	Automation	Function
48	Sure?	None	Info
49	YES	[0→1] write a "1" to take.	This Accepts the "DELETE THIS BUG" Request.
50	NO	None	This Declines the "DELETE THIS BUG" Request.
51	<BACK>	None	This Returns to menus#8→23.

Menus 52-55 Fade to black menus

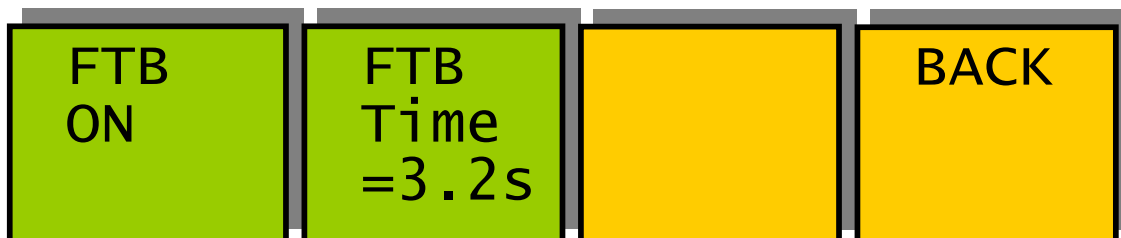

Menu Num.	Heading	Automation	Function
52	FTB: {status}	[0→1] 0=Fade to Prog 1=Fade to Black	This is effectively the "Take" button causing a fade FROM black or a fade TO Black.
53	FTB Time	0 Secs→ 20 Secs [0→200] (1/10 th sec's)]	This indicates the time taken to fade to and from black.

	Nn Sec		
54		None	Blank
55	<BACK>	None	This Returns to menu 64

Menus 56-59 Miscellaneous menu nests

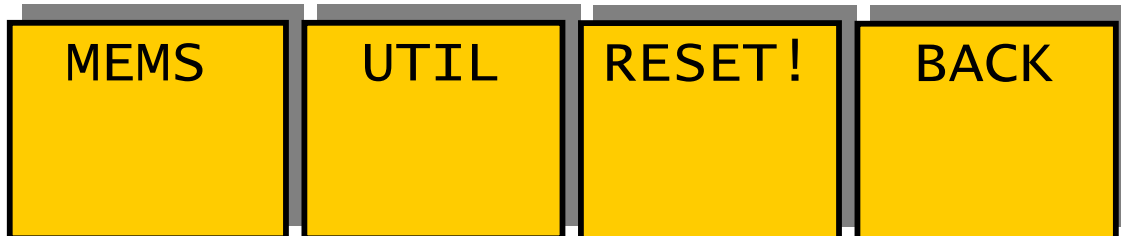

Menu Num.	Heading	Automation	Function
56	MEMS	None	This takes the user to menus#72→87. These menus enable use of the 6 internal Memories.
57	UTIL	None	This takes the user to menus#60→67. These menus are for some of the added value features of the unit.
58	RESET!	None	This takes the user to menus#88→91. These are for Power on reset settings and Total Reset (First Birthday)
59	<BACK>	None	This Returns to menus#0→3.

Menus 60-63 Preview safe area generator menus

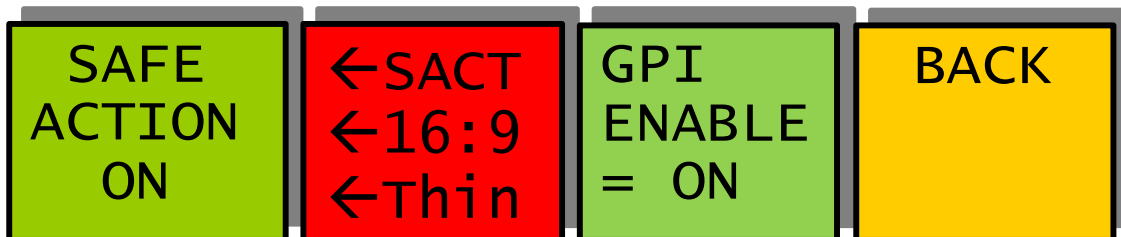

Menu Num.	Heading	Automation	Function
60	Safe Action Area Safe Caption Area Digital Edge Indicate Analogue Edge Indicate	On Off [0→1]	This Switches on and off the currently selected area. Pressing the "Red" switch next to this one and adjusting the rotary digipots with the lighted green LED's chooses the Selected area. NOTE THIS ONLY BECOMES VISIBLE IN "EDIT" MODE (CAPTURE MODE).

61	Area selected by menu#60	Digipot A S.Action S.Capt. Dig Edge An Edge [0→3]	When this button is pressed to "Green". The Three-line display in the window indicates the three options, which can be changed by adjusting the three rotary digipots A, B and C.
		Digipot B 4:3 16:9 16p4:3 16p149 43p16:9 [0→4]	Determines the basic Function Selects "Safe Action" option Selects "Safe Caption" option Selects "Digital Edge" option Selects the "An. Edge" option Determines the Screen Format Standard 4:3 Screen Standard 16:9 Screen 16:9 Shoot to protect 4:3 16:9 Shoot to protect 14:9 (*) 4:3 Shoot to protect 16:9 (*) (* -- Not available in 525)
		Digipot C Thin Thick Shade Black [0→3]	Determines the Style of Indicate Thin White lines are used Thick White lines are used Shade is used for "danger area" Black is used for "danger area"
62	GPI Enable	[0→1] 0=off 1=on	This enables or disables the GPI inputs.
63	<BACK>	None	This Returns to menus#56→59.

Menus 64-67 EDH and keying mode menus

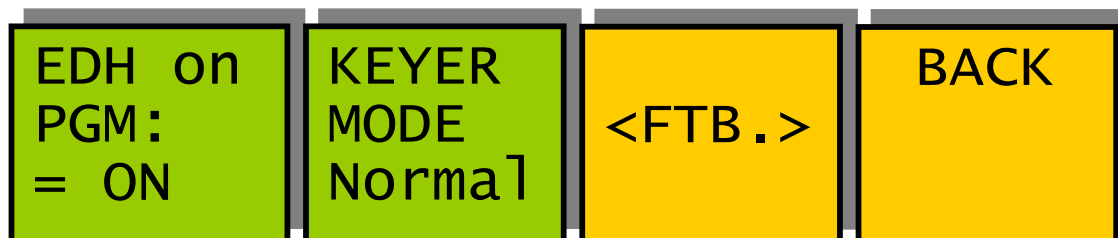

Menu Num.	Heading	Automation	Function
64	Enable EDH on Output	[0→2] 0=OFF 1=ON	This enables the EDH on the main program output.
65	KEYER MODE: <Normal/Additive Mix>	[0→1] 0=off 1=on	This Sets the internal keyer used for the Bug Keying to normal (Multiplicative) or Additive Mixing.

66	Fade To Black		Go To fade To Black menus.
67	<BACK>	None	This Returns to menus#56→59.

Menus 68-71 Animation set up menus

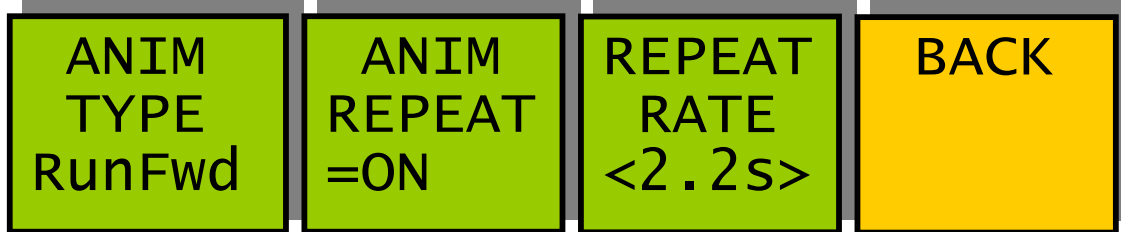

Menu Num.	Heading	Automation	Function
68	ANIM TYPE	[0→4] 0=No Anim 1=Run Fwd 2=Run Bwd 3=Loop 4=Bounce	This determines the way that the animation is played when it is stored in a play list. For a still frame this will report "No Anim". Run Fwd=The animation will run from the start frame to the end frame and stop Run Bwd=The animation will run from the end frame to the start frame and stop. Loop=The animation will run from the start frame to the end frame and then start again in a continuous loop. Bounce=The animation will run from the start frame to the end frame and then from the end frame to the start frame and so on in a continuous loop.
69	ANIM REPEAT <On/Off>	[0→1] 0=off 1=on	If this is ON this will cause the animation to reset to the start every nn seconds, where nn is set in menu#70.
70	REPEAT RATE nn Secs	[1→99]	If menu#69 is "ON" the animation will restart every "nn" seconds.
71	<BACK>	None	This Returns to menus#8→23 (16)

Menus 72-75 Memory 1→3 menus (NEXT to navigate)

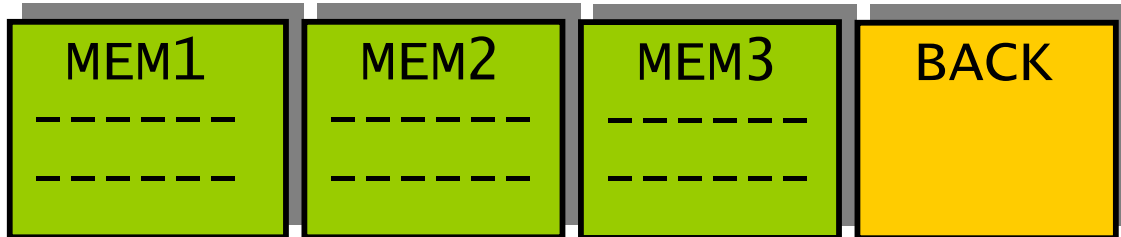

Menu Num.	Heading	Automation	Function
72	MEM1	1=Recall	Pressing this will recall Memory number 1. User Names can be programmed in to the memories using a keyboard. See “geNETics User guide”, section “Giving product Memories names”
73	MEM2	1=Recall	Pressing this will recall Memory number 2.
74	MEM3	1=Recall	Pressing this will recall Memory number 3.
75	BACK	none	Go To the Top Level Menus

Menus 76-79 Memory 4→6 menus (NEXT/PREV to navigate)

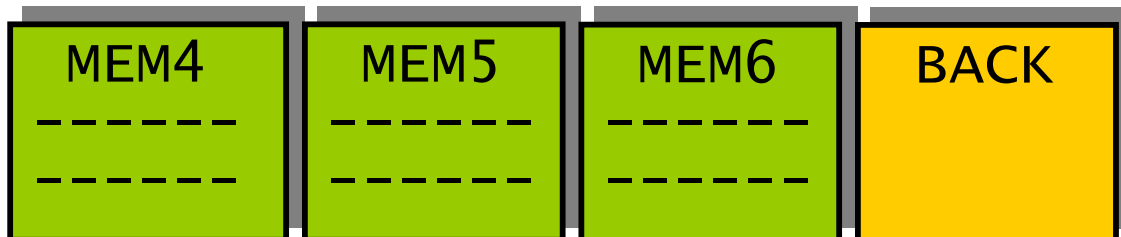

Menu Num.	Heading	Automation	Function
76	MEM4	1=Recall	Pressing this will recall Memory number 4.
77	MEM5	1=Recall	Pressing this will recall Memory number 5.
78	MEM6	1=Recall	Pressing this will recall Memory number 6.
79	BACK	none	Go To the Top Level Menus

Menus 80-83 Save memory 1→3 menus (NEXT/PREV to navigate)

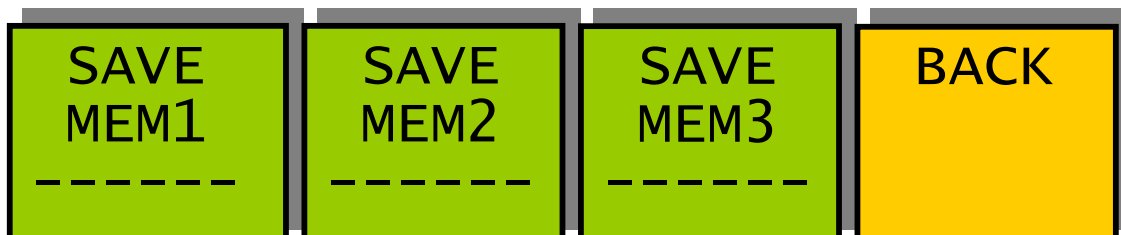

Menu Num.	Heading	Automation	Function
80	SAVE MEM1	1=Save	Pressing this will Save Memory number 1.
81	SAVE MEM2	1= Save	Pressing this will Save Memory number 2.
82	SAVE MEM3	1= Save	Pressing this will Save Memory number 3.
83	BACK	none	Go To the Top Level Menus

Menus 84-87 Save memory 4→6 menus (NEXT/PREV to navigate)

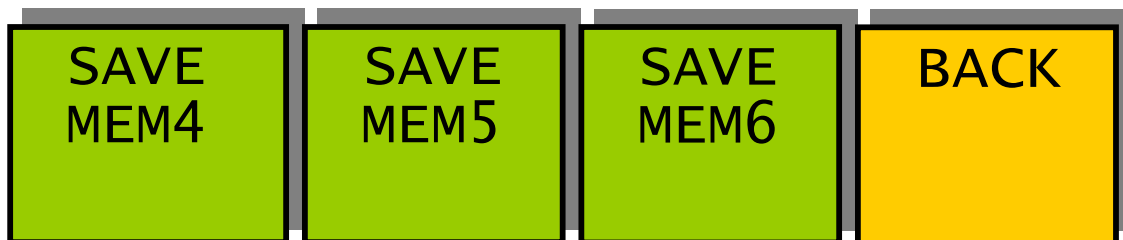

Menu Num.	Heading	Automation	Function
84	SAVE MEM4	1= Save	Pressing this will Save Memory number 4.
85	SAVE MEM5	1= Save	Pressing this will Save Memory number 5.
86	SAVE MEM6	1= Save	Pressing this will Save Memory number 6.
87	BACK	none	Go To the Top Level Menus

Menus 88-91 Software version menu

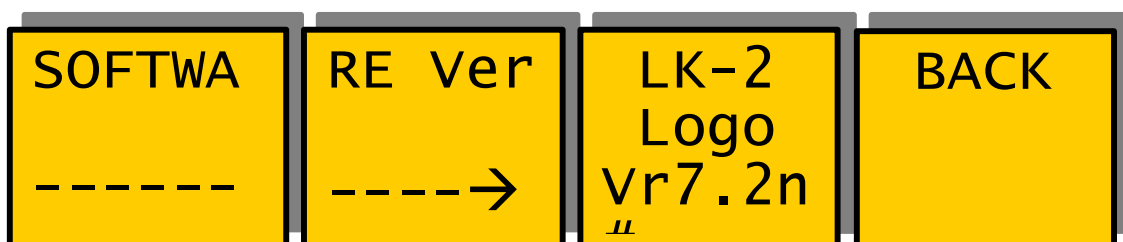

Menu Num.	Heading	Automation	Function
88	Info	none	Information
89	Info	none	Information
90	none	none	Software Version Information
91	BACK	none	Go To the Top Level Menus

Menus 92-95 Power on memory menus



Menu Num.	Heading	Automation	Function
95	Set As Pow On Memory	1=Set	Pressing this will set the current system set-up as the Power on memory default.
96	Recall Pow On Memory	1=Recall	Pressing this will recall The Power-on memory set up in the last menu.
97	Total Reset	1=Reset	Pressing this will cause a first Birthday of the unit. All current memories and settings will be lost.
98	BACK	none	Go To the Top Level Menus

4 Technical Appendix

4.1 GPI/Tally/RS232 technical information.

Pin#	Function
1	General Purpose Output #1a (GPO1a). Isolated Relay closure. Tally Out “Logo On Air”
2	General Purpose Output #1b (GPO1b). Isolated Relay closure. Tally Out “Logo On Air”
13	General Purpose Input #1 (GPI1). Pull to Ground to activate. This will Activate Play#1 Bug to Air.
14	General Purpose Input #2 (GPI2). Pull to Ground to activate. This will Activate Play#2 Bug to Air.
15	General Purpose Input #3 (GPI3). Pull to Ground to activate. This will Activate Play#3 Bug to Air.
16	General Purpose Input #4 (GPI4). Pull to Ground to activate. This will Activate Play#4 Bug to Air.
17	General Purpose Input #5 (GPI5). Pull to Ground to activate. This will Activate Play#5 Bug to Air.
18	General Purpose Input #6 (GPI6). Pull to Ground to activate. This will Activate Play#6 Bug to Air.
19	General Purpose Input #7 (GPI7). Pull to Ground to activate. This will Activate Play#7 Bug to Air.
20	General Purpose Input #8 (GPI8). Pull to Ground to activate. This will De-activate the current Play# From Air.
25	GND

Table 1 Rear 25 Way D-type Pinout

GPI's are short to Ground (pin 25) to activate. They require MOMENTARY operation only. At least 100mS pulse. Activation begins on the leading edge.

4.1.1 GPI Inputs.

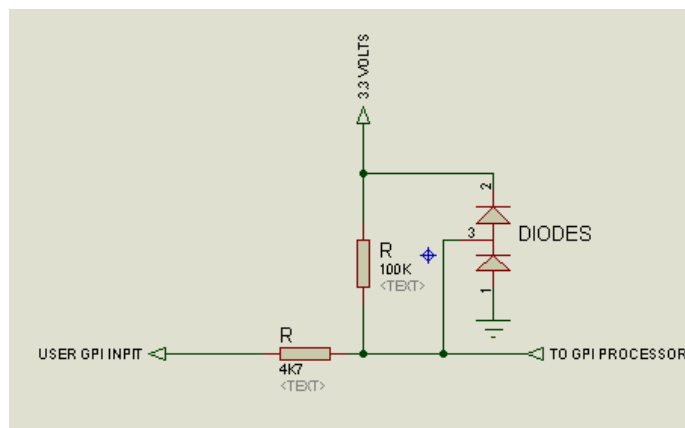

Figure 11 Typical GPI Input

GPI's are normally activated by a short to ground. The GPI has its own internal pull-up resistor. If the user is interfacing with logic then

- Vhigh = +12V>Vin>+3V
- Vlow = +0.3V>Vin>0V

4.1.2 Tally Output.

This is a fully isolated pair of relay contacts. 24V, 0.5 Amp Max rating.

4.2 geNETics Automation Protocol Parameter table.

Menu	Access	Text	Low	Up	Lev	Txt1	Txt2	Txt3	Txt4	Txt5
0	N/A	{<PLAY>}{<LK-2>}{ }	N/A	N/A	A					
1	N/A	{<EDIT>}{-bug-}{ }	N/A	N/A	A					
2	N/A	{<INFO>}{ unit }{ }	N/A	N/A	A					
3	N/A	{<MISC>}{ PrTx>}{ }	N/A	N/A	A					
4	R/W	{ TAKE }{# }	0	2	A	< ON >	< OFF >	< TRAN >		
5	R/W	{NXT:# }	0	Variable	A					
6	R/W	{AuTran}{Time=}{# Fr}	1	240	A					
7	N/A	{ BACK }{=play=}{ }	N/A	N/A	A					
8	RD	{ Bugs }{Stored}{=# } {ACQUIRE}{ NEW }{ BUG	0	10000	A					
9	N/A	}} {DELETE}{STORED}{	N/A	N/A	A					
10	N/A	BUG }}	N/A	N/A	A					
11	N/A	{ BACK }{=edit=}{ }	N/A	N/A	A					
12	R/W	{BUG:# }	0	Variable	A					
13	R/W	{H-POSn}{<# >}	0	1440	A					
14	R/W	{V-POSn}{<# >}	0	575	A					
15	N/A	{ BACK }{=edit=}{ } { ANIM }{TRIM-H}{<#	N/A	N/A	A					
16	RD	>}	Variable	Variable	A					
17	RD	{ ANIM }{TRIM-L}{<# >} { ANIM }{ PLAY	0	Variable	A					
18	N/A	}{MODES}}	N/A	N/A	A					
19	N/A	{ BACK }{=edit=}{ }	N/A	N/A	A					
20	RD	{START }{ANIM'n}{# }	0	1	A	PREV'W	OK!			
21	N/A	{ADD TO}{ PLAY }{ LIST}} {DELETE}{ PLAY }{	N/A	N/A	A					
22	N/A	ITEM}}	N/A	N/A	A					
23	N/A	{ BACK }{=edit=}{ }	N/A	N/A	A					
24	N/A	{SURE?}{ }{ }	N/A	N/A	A					
25	R/W	{# }	0	1	A	YES	OK!			
26	N/A	{NO }{ }{ }	N/A	N/A	A					
27	N/A	{ BACK }{=edit=}{ }	N/A	N/A	A					
28	R/W	{PLAY# }	0	Variable	A					

29	RD	{P-list}{Stored}{=# }	0	10000	A														
30	N/A	{DELETE}{ THIS }{ PLAY}}	N/A	N/A	A														
31	N/A	{ BACK }{=edit={ }	N/A	N/A	A														
32	N/A	{SURE?}{ }{ }	N/A	N/A	A														
33	R/W	{# }	0	1	A	YES	OK!												
34	N/A	{NO }{ }{ }	N/A	N/A	A														
35	N/A	{ BACK }{=edit={ }	N/A	N/A	A														
36	R/W	{LEFT: }{<# >}	4	716	A														
37	R/W	{RIGHT: }{<# >}	4	716	A														
38	R/W	{TOP: }{<# >}	0	576	A														
39	R/W	{BOTTOM}{<# >}	0	576	A														
40	RD	{Num.Of}{Frames}{=# }	0	0	A														
41	RD	{ACQUIRE}{MODE:=}{# }	0	1	A	Grab	CueDot												
42	R/W	{# }	0	6	A	!GRAB!	VIDEO>	!WAIT!	VIDEO	KEY >									
42	RD	{# }	0	6	B	!!GO!!	READY	!DONE!	READY!									
43	N/A	{ BACK }{=edit={ }	N/A	N/A	A														
44	R/W	{BUG:# }	0	Variable	A														
45	RD	{ Bugs }{Stored}{=# }	0	10000	A														
46	N/A	{DELETE}{ THIS }{ BUG }	N/A	N/A	A														
47	N/A	{ BACK }{=edit={ }	N/A	N/A	A														
48	N/A	{SURE?}{ }{ }	N/A	N/A	A														
49	R/W	{# }	0	1	A	YES	OK!												
50	N/A	{NO }{ }{ }	N/A	N/A	A														
51	N/A	{ BACK }{=edit={ }	N/A	N/A	A														
52	R/W	{ FTB: }{# }	0	1	A	<OFF>	<ON!>												
53	R/W	{ FTB }{Time }{=# S}	0	200	A														
54	N/A	{ }{ }{ }	N/A	N/A	A														
55	N/A	{ BACK }{=ftb=}{ }	N/A	N/A	A														
56	N/A	[Gr]	N/A	N/A	A														
57	N/A	[Gr]	N/A	N/A	A														
58	N/A	[Gr]	N/A	N/A	A														
59	N/A	{ BACK }{=misc={ }	N/A	N/A	A														
60	RD	{# }	0	3	A	SAFE	SAFE	DIGITAL	ANALOG										
60	RD	{# }	0	3	B	ACTION	CAPT'N	EDGE	EDGE										
60	R/W	{# }	0	1	C	OFF	ON												
61	R/W	{# }	0	3	A	[S.Act	[S.Cap	[D.Edg	[A.Edg										
61	R/W	{# }	0	4	B	[4:3	[16:9	16p4:3	16p149	43p149									
61	R/W	{# }	0	3	C	[Thin	[Thick	[Shade	[Black										
62	R/W	{GPI }{ENABLE}{# }	0	1	A	= OFF	= ON												
63	N/A	{ BACK }{=util={ }	N/A	N/A	A														
64	R/W	{EDH On}{PGM: }{# }	0	1	A	= OFF	= ON												
65	R/W	{KEYER }{MODE }{# }	0	1	A	Normal	AddMix												
66	N/A	{ }{ <FTB.>}{ }	N/A	N/A	A														
67	N/A	{ BACK }{=util={ }	N/A	N/A	A														
68	R/W	{ ANIM }{ TYPE }{# }	0	4	A	NoAnim	RunFwd	RunBwd	Loop	Bounce									
69	R/W	{ ANIM }{REPEAT}{# }	0	1	A	=OFF	=ON												
70	R/W	{REPEAT}{ RATE }{<# S>}	1	99	A														
71	N/A	{ BACK }{=edit={ }	N/A	N/A	A														
72	R/W	{%> }{ }{# }	0	1	A	(Mem1)	(OK)												
73	R/W	{%> }{ }{# }	0	1	A	(Mem2)	(OK)												
74	R/W	{%> }{ }{# }	0	1	A	(Mem3)	(OK)												
75	N/A	{ BACK }{=mems={ }	N/A	N/A	A														

76	R/W	{%>\$}{ }{# }	0	1	A	(Mem4)	(OK)				
77	R/W	{%>0}{ }{# }	0	1	A	(Mem5)	(OK)				
78	R/W	{%><}{ }{# }	0	1	A	(Mem6)	(OK)				
79	N/A	{BACK}{=mems={ }	N/A	N/A	A						
80	R/W	{# }	0	1	A	Save	DONE!				
81	R/W	{# }	0	1	A	Save	DONE!				
82	R/W	{# }	0	1	A	Save	DONE!				
83	N/A	{BACK}{=mems={ }	N/A	N/A	A						
84	R/W	{# }	0	1	A	Save	DONE!				
85	R/W	{# }	0	1	A	Save	DONE!				
86	R/W	{# }	0	1	A	Save	DONE!				
87	N/A	{BACK}{=mems={ }	N/A	N/A	A						
88	N/A	{SOFTWA}{----}{ }	N/A	N/A	A						
89	N/A	{RE Ver}{----}{ }	N/A	N/A	A						
90	N/A	{!}{ }{ }	N/A	N/A	A						
91	N/A	{BACK}{=LK-2={ }	N/A	N/A	A						
92	R/W	{# }	0	1	A	Set As	WAIT!!				
93	R/W	{# }	0	1	A	Recall	WAIT!!				
94	R/W	{# }	0	1	A	TOTAL!	WAIT!!				
95	N/A	{BACK}{=reset}{ }	N/A	N/A	A						
96	RD	{Next:}{Bug#	0	Variable	A						
97	N/A	{Name:}{ }{ }	0	Variable	A						
98	R/W	{# }	0	3	A	[Gr]	[Gr]	[Gr]	[Gr]		
99	R/W	{User}{TrTime}{=# fr}	1	240	A						
100	N/A	{BUG}{ }{ }	N/A	N/A	A						
101	N/A	{TRANS}={ TIME}{ }	N/A	N/A	A						
102	R/W	{# }	1	200	A						
103	N/A	{Frames}{ }{ }	N/A	N/A	A						
104	N/A	{BUG}{ }{ }	N/A	N/A	A						
105	RD	{#1 }	N/A	N/A	A						
106	N/A	{TRA}{ }{ }	N/A	N/A	A						
107	N/A	{NS}{.....}{.....}	N/A	N/A	A						
108	N/A	{BUG}{ }{ }	N/A	N/A	A						
109	RD	{#2 }	N/A	N/A	A						
110	N/A	{TRA}{ }{ }	N/A	N/A	A						
111	N/A	{NS}{.....}{.....}	N/A	N/A	A						
112	N/A	{DO NOT}{DoThis}{ON AIR}	N/A	N/A	A						
113	N/A	{THINK!}{THINK!}{ }	N/A	N/A	A						
114	N/A	[Gr]	N/A	N/A	A						
115	N/A	{BACK}{(SAFE)}{ }	N/A	N/A	A						
116	N/A	{BUG}{ }{ }	N/A	N/A	A						
117	RD	{#3 }	N/A	N/A	A						
118	N/A	{TRA}{ }{ }	N/A	N/A	A						
119	N/A	{NS}{.....}{.....}	N/A	N/A	A						

4.3 Technical Specification.

When in SDI mode:

SDI Inputs (270 Mbps, 800mV p-p±10% into 75Ω)	1 Input to SMPTE 259M
SDI Outputs (270 Mbps, 800mV p-p±10% into 75Ω)	1 Outputs to SMPTE 259M
SDI cable equalisation	At least 200m of PSF 1/3 Return loss better than 18dB, 5 MHz – 270 Mhz

General:

Ancillary Data	Passes all ancillary data in vertical and horizontal blanking except for CRC recalculation.
Control Surfaces	Option of local or remote FP-9 control panel.
Chassis	FB-9E etherBox 1U enclosure
Delay	<10us
Power Supply	100-240v AC. Less than 50W power consumption with 6 LK-2 units installed.
FB-9E Dimension	Width 442mm Height 44mm Depth 300mm
Weight	<3Kg
Temperature	<25°C ambient, <55°C internal
Humidity	Recommended 40 to 55% Limits 20 to 80%