

Last updated 17/12/2000:

# PRODUCT USER GUIDE FOR: THE WR-2 VIDEO TYPEWRITER

## Table Of Contents:

|   |    |
|---|----|
| Video Writer System-Overview.....                                     | 2  |
| Installation of the BL-1 Product.....                                 | 3  |
| Installing the BL-1 into a Flexibox .....                             | 3  |
| Video Writer System Processing.....                                   | 3  |
| WR-2 Video Writer Processing Block Diagram .....                      | 4  |
| Operating the Video Writer using the Keyboard.....                    | 4  |
| Switching between Text and on Screen Menu Modes.....                  | 4  |
| The On-Screen Menu System .....                                       | 4  |
| Menus for the WR-2 Unit .....   | 6  |
| WR-2 Configuration of the Serial Digital I/O cards .....              | 9  |
| Appendix-A Configuration of the Serial Digital I/O cards .....        | 9  |
| Technical Specification for the SIO-1/2 Dual Serial Digital Card..... | 10 |
| Technical Spec for the SIO-1/2 SDICard .....                          | 10 |
| Jumpering the I-BUS (CAN-BUS) Termination .....                       | 10 |

## **Video Writer System-Overview**

The WR-2 is a Character Inserter Unit based loosely on the LD-1 (Loss Ident Unit). The WR-2 unit will superimpose a block of text of up to 64 Characters over a live video input. Because product code ends in "-2", only one channel of this product can fit onto a single Eurocard. (All Eyeheight geNETics products with the code ending in "-1" can be configured as dual channel systems, products ending with "-2" can only be configured as single channel systems.)

The unit physically consists of an I/O card connected together with a Processor card making a 220mm long Eurocard.

The I/O card is a single SDI I/O card (SIO-1) for a single unit, or a dual SDI I/O card for a dual unit (SIO-2). This will be configured to have a single SDI Input, an optional SDI input loop and one or two SDI Outputs, which are functionally the same.

The SIO-1/2 card configuration options are described in Appendix A. The Processor card is a standard processor (PROC-2) card that implements the Video Writer system.

The main features of the WR-2 are as follows:

- This unit superimposes up to a 64 Character text message onto the incoming live video feed.
- The unit can be operated entirely from a PS-2 Keyboard with "On-Screen Menus".
- A Text Edit mode is used for text entry from the keyboard.
- Internal Test Signal Generator with a choice of 8 test signals.
- Choice of character colour and background.
- Automation Control.
- 4 User Memories store all text and user settings.

## **Installation of the BL-1 Product**

If this unit is already pre-installed in a Flexibox (FB-9) with either a local or remote panel from the Factory then refer to the "Hardware Installation Guide" which will be enclosed with the system.

If this unit has been ordered separately we assume here that you already have a Flexibox system with a Flexipanel and that the Flexibox has at least one "Spare Slot" for the BL-1 card.

## **Installing the BL-1 into a Flexibox**

To install the BL-1 into a flexibox it is not necessary to power down the box. Follow these instructions.

1. On the rear of the flexibox are 6 slots for Products. Remove any spare blanking plate on an unused slot. There are 2 M2.5 Screws, which require unfastening.
2. Slide the Product PCB into the spare slot and firmly push it "home".
3. Use the two thumbscrews to fasten the unit in place.
4. Now refer to the "GeNETics User Guide". If your system consists of a single Flexibox with a single Flexipanel then refer to the section titled "Flexipanel Auto Set-up". If your system is part of a network with more than one Flexipanel then refer to the section titled "Flexipanel Manual Set-up". This will guide you through acquiring your product as a device on the Flexipanel.

## **Video Writer System Processing**

This unit consists of four parts:

1. A "loss of video detector" that senses Sync loss. Control from this is used to switch from the live video input to the internal test signal generator (TSG).
2. A "Test signal generator", free-running on its own sync generator.
3. A "Character overlay" block of 16 Characters used for the on-screen menu.
4. A "Character overlay" block of 64 Characters used for the main text message area.

Upon Loss of input signal, the "Sync loss detection unit" will force the 2 by 1 switch to take the TSG output rather than the live video input. This also enables the "Character overlay". Both the "Sync loss detection unit" and the "Character overlay" can also be forced on or off by the software providing further functionality such as permanent TSG output.

## WR-2 Video Writer Processing Block Diagram

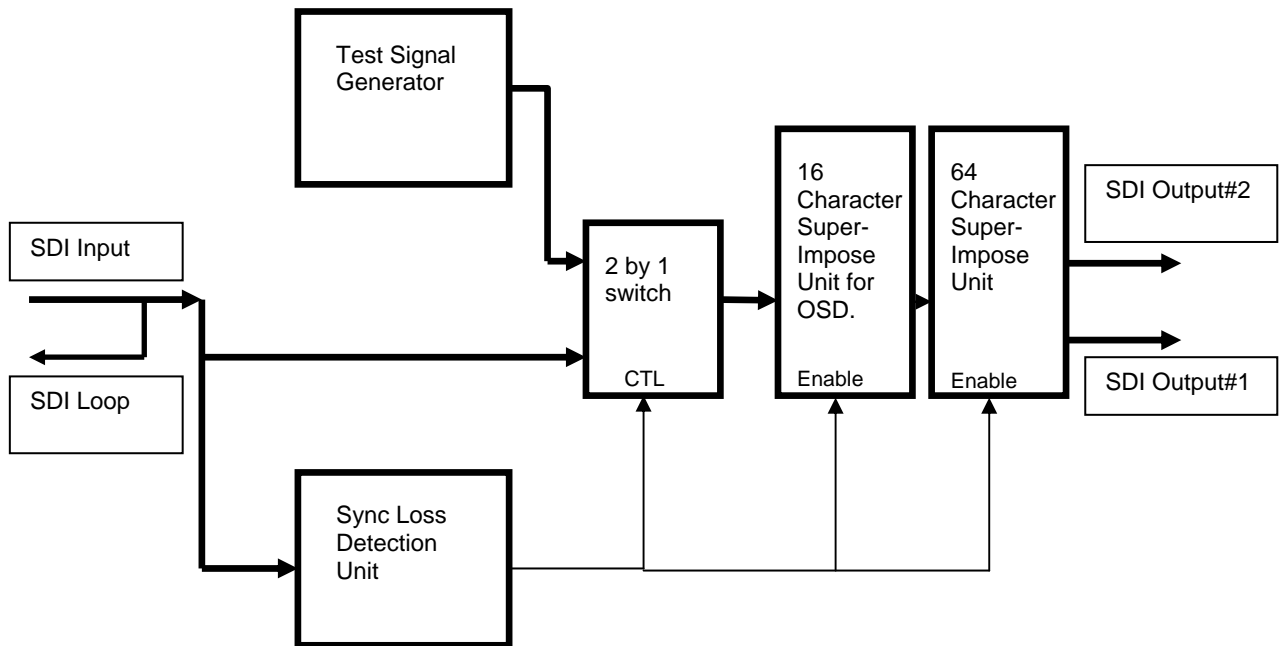

## Operating the Video Writer using the Keyboard

The Video Writer WR-2 is designed to operate entirely from a PS-2 Keyboard (Eyeheight Order code KB-9) using the On-Screen menu system and the Text Editor. The KB-9 plugs into the PS-2 port of the Eyeheight FP-9 Flexipanel. The Flexipanel can be mounted either locally on the front of the IRU Chassis (FB-9) or remotely using the I-Bus Network port. The Flexipanel can also be used to control the system set-ups (Menus) but text entry is always via the Keyboard.

The following list explains the operation of the Keyboard.

### Switching between Text and on Screen Menu Modes

The "ESCAPE" key switches between Text Editing mode and On-Screen menu modes. In On-Screen menu mode a 16 Character text menu will appear on the screen. This menu can be positioned by the user using the menus.

### The On-Screen Menu System

The following keys operate the On-Screen menu System:

- ⌚ "UP ARROW" This key takes you to the next menu. Pressing "SHIFT" at the same time will take you to the last menu.
- ⌚ "DOWN ARROW" This key takes you to the previous menu. Pressing "SHIFT" at the same time will take you to the first menu.
- ⌚ "LEFT ARROW" This key adjusts the current menu down one increment. Pressing "SHIFT" at the same time will adjust the menu down by 10 increments.
- ⌚ "RIGHT ARROW" This key adjusts the current menu up by one increment. Pressing "SHIFT" at the same time will adjust the menu by up by 10 increments.

### **The On-Screen Menu System**

The following keys operate the Text Editing System:

- ⌚ "UP ARROW" This key places the text editing cursor up one line. Pressing "SHIFT" at the same time will place the cursor on the first line.
- ⌚ "DOWN ARROW" This key places the text editing cursor down one line. Pressing "SHIFT" at the same time will place the cursor on the last line.
- ⌚ "LEFT ARROW" This key places the text editing cursor one place to the left. Pressing "SHIFT" at the same time will place the cursor on the first character of the current line.
- ⌚ "RIGHT ARROW" This key places the text editing cursor one place to the right. Pressing "SHIFT" at the same time will place the cursor on the last character of the current line.
- ⌚ "INSERT" This key will insert a space character at the current cursor position.
- ⌚ "DELETE" This key will delete the character at the current cursor position.
- ⌚ "HOME" This key will place the cursor at the first position of the first line.
- ⌚ "END" This key will cause the text cursor to disappear. The Text cursor is actually placed one character further than the last position of the last line. Pressing "LEFT ARROW" will reveal the cursor at the last position of the last line.
- ⌚ "F1" This key will clear the current text screen.

## Menus for the WR-2 Unit

The WR-2 has the following menu structure. Automation control also is implicit in the menu structure. Refer to the "GeNETics User Guide" in the section titled "Automation Protocol on the geNETics Platform" for detailed information. The values given in square brackets indicate the values for Automation system purposes.

NOTE: These menus apply to the On-Screen menu system and the Flexipanel menu structure.

| Menu # | Function                           | Range of Value  | Notes  |
|--------|------------------------------------|---|--|
| 0      | Unit Title (Video Writer System)   | None  |  |
| 1      | Not Used-Information only          | None  |  |
| 2      | Not Used-Information only          | None  |  |
| 3      | Not Used-Information only          | None  |  |
| 4      | On Screen Menu Horizontal Position | 4→720<br>[4→720]  | This parameter moves the On-Screen Menu from left to right.  |
| 5      | On Screen Menu Vertical Position   | 0→280<br>[0→280]  | This parameter moves the On-Screen Menu from top to bottom.  |
| 6      | Test Signal Select                 | Y Ramp<br>C Ramp<br>U Ramp<br>V Ramp<br>SDI Matrix<br>Y/C Ramp<br>U/V Ramp<br>100%Bars<br>[0→7] | This selects the Test Signal which is generated.   |
| 7      | System Mode                        | Char Super<br>Force TSG<br>[0→1]  | This menu determines the basic mode of operation of the unit. This can either be:<br><br>0-Character Super-impose unit. This will superimpose the 64 character text onto the live video input and also output the TSG if the input fails.<br>Force TSG. This forces the TSG to be output regardless of the input status. |
| 8      | Text Mode                          | Off<br>Boxed<br>Char<br>[0→2]   | This determines the text presentation as either permanently off, Characters with a boxed background, or characters only.   |
| 9      | Text Format                        | 2 by 32<br>3 by 21<br>4 by 16<br>5 by 12<br>6 by 10<br>7 by 9                                   | This sets the number of text lines (2,3,4,5,6,7 or 8) along with the maximum number of characters per line. (32,21,16,12,10,9,8 respectively)  |

|       |                               |   |   |
|-------|-------------------------------|---|---|
|       |                               | 8 by 8<br>[0→3]   |   |
| 10    | Text Colour                   | White<br>Yellow<br>Cyan<br>Green<br>Purple<br>Red<br>Blue<br>Black<br>[0→7] | Indicates the character overlay character colour.   |
| 11    | Box Colour                    | Black<br>Blue<br>Red<br>Purple<br>Green<br>Cyan<br>Yellow<br>White<br>[0→7] | Indicates the character overlay background box colour.  |
| 12    | Horizontal Character Position | 4→720<br>[4→720]  | This parameter moves the characters from left to right.   |
| 13    | Vertical Character Position   | 0→280<br>[0→280]  | This parameter moves the characters from top to bottom.   |
| 14    | Character Width               | 0→31<br>[0→31]  | This adjusts the width of the characters from 0 (small, approx. teletext standard width) to 31 (huge!)  |
| 15    | Character Height              | 0→31<br>[0→31]  | This adjusts the Height of the characters from 0 (small, approx. teletext standard height) to 31 (huge!)  |
| 16→19 | Recall Memory #1→4            | [Automation must write a "1" to cause a recall Memory command]              | Pressing this will overwrite all current settings in favour of those settings saved when the "Save Memory#1→8" Buttons (respectfully) was pressed   |
| 20→23 | Save Memory #1→4              | [Automation must write a "1" to cause a save Memory command]                | Pressing this will store all current settings in Memory#1→8.  |
| 24    | Info "These menus Pass"       | None  |   |
| 25    | Info "Control Elsewhere"      | None  |   |
| 26    | Pass Control Enable           | None  | This causes control to be passed to one or two flexipanel on the same I-BUS network with "panel numbers" shown in the next red LCD Window. When control is passed you will see the middle and lower lines of the LCD Display say either "OK" or "FAIL" depending on whether control was successfully passed on to either of the selected panels. Further presses of this button will enable or disable the control. |

|    |   |   |   |
|----|---|---|---|
| 27 | <p>"Panel" numbers to which control can be passed.</p> <p>This feature is used to pass temporary control over to another panel. Upon passing temporary control over to another panel, that panel will have a flashing "device button LED" indicating that control is available on this device button.</p> | <p><u>Digipot A</u><br/>0→58<br/>[0→58]</p> <p><u>Digipot B</u><br/>0→58<br/>[0→58]</p> | <p>When this button is pressed, it changes to "Green". The Three-line display in the window then indicates the two options, which can be changed by adjusting the two rotary digipots A and B.</p> <p>This will alter the first panel number to which you would like to pass control.</p> <p>This will alter the second panel number to which you would like to pass control.</p> <p>The panel number of any panel can be found by pressing the set-up button momentarily. Setting either of the above panel numbers to "0" will stop any control being passed.</p> |
| 28 | Save PowON mem  | [Automation must write a "1" to cause a recall Memory command]                          | Saves the current settings to be the "power on reset" settings  |
| 29 | Recall PowON mem  | [Automation must write a "1" to cause a recall Memory command]                          | Recalls the "power on reset" settings   |
| 30 | <p>"Total Reset ".</p> <p>Note also there is a number like "K15090" This is a software version of the GeNETics product's "Kernel"</p>   | [Automation must write a "1" to cause a recall Memory command]                          | This puts all current and power on default settings to the factory default  |
| 31 | Info - Software Versions  | None  | This shows the Software Versions of the unit.   |

Note: For automation control of menus 16→27, writing a "1" into this menu will cause the same action as a button press.

## WR-2 Configuration of the Serial Digital I/O cards

All GeNETics Products have exchangeable I/O cards. The WR-2 is supplied with the SIO-1 Card. The following table shows the jumper settings on the PCB for the factory delivered unit. This configuration gives the user 2xWR-2 main outputs and an active SDI input loop on channel A.

| Rear Legend          | Explanation                 | Jumper settings         |
|----------------------|-----------------------------|-------------------------|
| IP-A                 | SDI Input of channel A      | None                    |
| A-LP<br>OP1A         | Input A active loop through | Jumper J6 to N          |
| OP2A<br>OP2B         | WR-2 Output number 1        | Jumper J3 to N          |
| B LP<br>OP1B<br>OP1A | WR-2 Output number 2        | Jumper J7 to E, J9 to S |
| IP-B                 | SDI Input of channel B      | None                    |

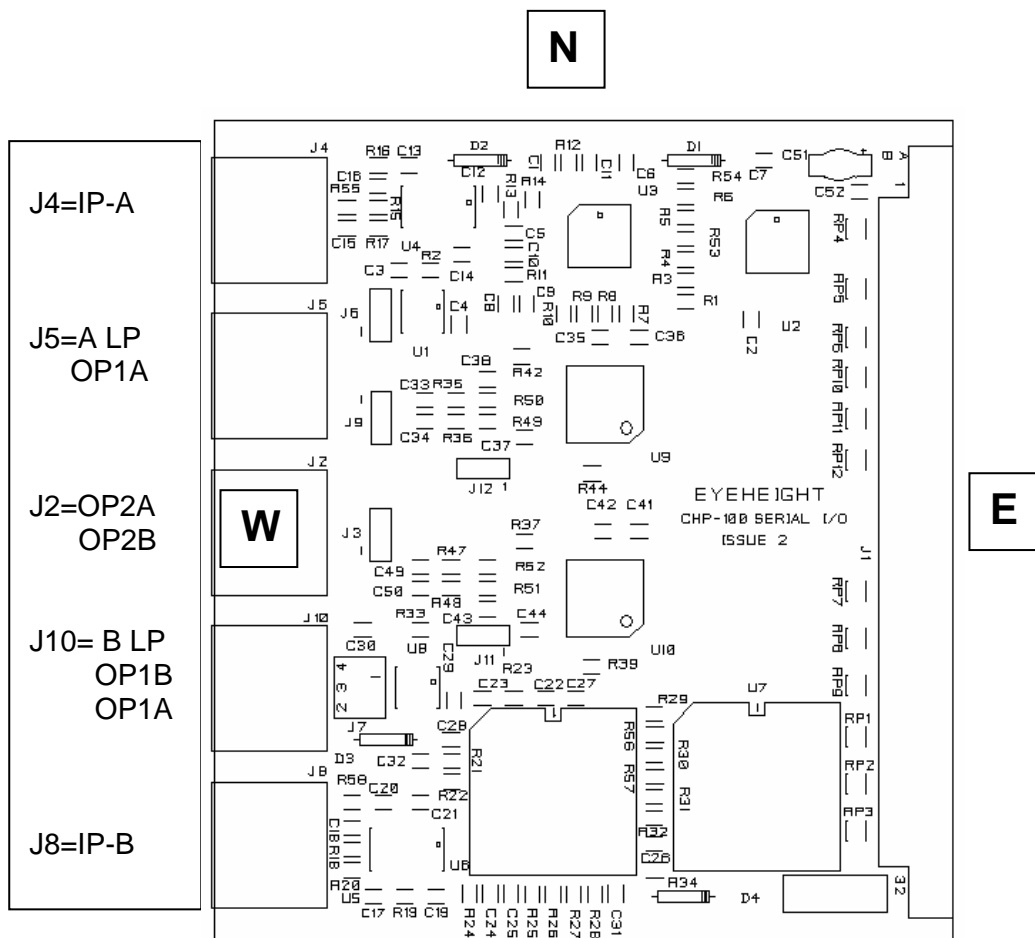

## **Technical Specification for the SIO-1/2 Dual Serial Digital Card**

|  |  |
|--|--|
| <b>Number of inputs</b>                | <b>2 (SIO-2) or 1 (SIO-1)</b>  |
| <b>Type of Inputs</b>                  | 270Mbit Serial Digital Video Inputs 75 Ohm   |
| <b>Line Length</b>                     | At least 200 Meters of PSF1/3 (Typically 275 Meters)   |
| <b>Number of Outputs</b>               | 3 Outputs per Card.  |
| <b>Type Of Outputs</b>                 | 270Mbit Serial Digital Video Outputs, 75 Ohm, 800mV  |
| <b>Total Number Of BNC Connections</b> | 5, consisting of 1 or 2 Fixed Inputs and 3 Jumper Configurable outputs.                                      |
| <b>SDI Output Jitter</b>               | The system will add less than 0.2UI to the input Jitter. (This is only guaranteed on issue 2 or later cards) |

### **Jumpering the I-BUS (CAN-BUS) Termination**

The I-BUS Network is the "control system" under which all Products and Panels are networked together. Under certain circumstances it is necessary to terminate the network. This can be done on a Flexi-panel or a "Product". Should the network require terminating at the point of this product. To terminate this product, locate J5 on the WR-2 Product supplied which is between U1 (The large square "chip") and the Edge connector. (This is on the half of the card labelled "CHP-100 Processor"). Jumper this with a 2mm Jumper link.

The user should read the "Hardware Installation Guide" to know if this link is to be jumpered.