



EM-4

AES audio option for playout

user manual

Table of Contents

1 System Overview	4
1.1 Applications for the EM-4	4
1.2 Associated Equipment for the EM-4.....	5
1.2.1 Chassis Types	5
1.2.2 Control Surfaces	5
2 Installation	7
2.1 Installation of the EM-4 product	7
2.2 Installing the EM-4 into a flexiBox	7
2.3 Connecting Video to an EM-4	7
2.4 Connecting Panels to the EM-4	8
3 Operation	10
3.1 Manual control of the EM-4.....	10
3.2 Automation Control of the EM-4.....	10
3.3 Operational Menus for the EM-4.....	11
4 Technical Appendix.....	15
4.1 Technical Specification for the EM-4.....	15
4.2 Jumpering the I-BUS (CAN-BUS) Termination	15
4.3 CHP-100 SDI-TC-GPI Card	16
4.3.1 Jumper Links on the Timecode and GPI I/O card	16

Table of Figures

Figure 1-1 The EM-4 Module.	4
Figure 1-2 FlexiBox with flexiPanel fitted.....	5
Figure 1-3 Desktop modular panel FP-10.	5
Figure 1-4 IRU panel FP-9.	6
Figure 2-1 Connections for the EM-4	8
Figure 2-2 I-Bus Connections and Termination.....	8
Figure 4-1 Location Of I-Bus Termination Link.....	16
Figure 4-2 jumpers on the EM-4 I/O card	16

I System Overview

This manual describes the function of the EM-4. This unit is an AES embedder and de-embedder designed to work with the MW-3E, mixer wipe unit. The system embeds AES audio onto the A and B SDI feeds to an Eyeheight MW-3E Mixer/Wipe module. (The MW-3E also mixes Embedded audio) hence effectively providing AES Audio mixing. The unit also contains a de-embedder to provide an AES output from the MW-3E or a unit further down the chain in an eyeheight **playout** system

The EM-4 Product

The EM-4 is a unit that will accept three standard SDI video inputs, and has four SDI outputs. Two of which are loop outputs, and the remaining two with embedded audio. The main features are :-

- 2 off Audio Embedders (AES into SDI).
- 1 off Audio De-embedder (AES from SDI).
- Audio Level controls.

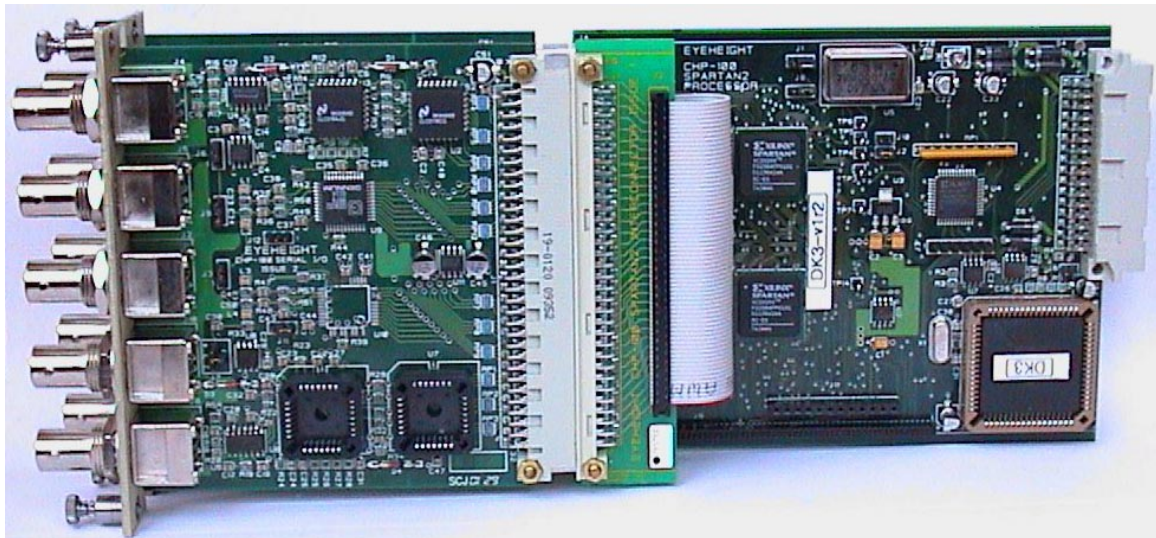

Figure 1-1 The EM-4 Module.

I.I Applications for the EM-4

Applications for the EM-4 include the following:-

- AES audio option for the PresTX system
- Embedding and de-embedding AES audio

I.2 Associated Equipment for the EM-4

The EM-4 is a module and requires both a chassis and a control surface to function.

I.2.1 Chassis Types

- **flexiBox** is a 1RU chassis. The order code is FB-9. This will hold a maximum of 3 EM-4 Modules with “Hot Swap” redundant PSU option and “Hot Swap” EM-4 modules.
- **maxiBox** is an alternative low cost 1RU chassis. The order code is MX-9. This also will hold a maximum of 3 EM-4 modules but it has no redundant PSU option and the EM-4 units must be factory fitted.

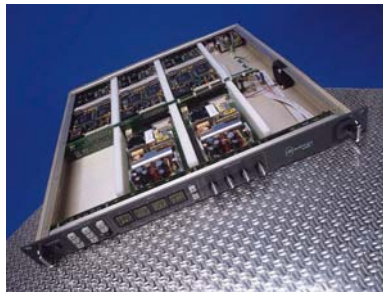

Figure 1-2 FlexiBox with flexiPanel fitted

I.2.2 Control Surfaces

- **flexiPanel** is a 1RU control surface that fits on the Front of a 1RU flexiBox. The order code is FP-9. A FlexiPanel can also be used in conjunction with a miniBox, in this case the extra accessory (Order code RR-9) will be required
- **FP-10** is a desk mounting control surface (Order code FP-10). This unit is a modular unit which can be used in conjunction with the units below.



Figure 1-3 Desktop modular panel FP-10.



Figure 1-4 IRU panel FP-9.

2 Installation

2.1 Installation of the EM-4 product

If this unit is already pre-installed in a flexiBox (FB-9), or a maxiBox, with either a local or a remote panel from the factory then refer to the "Hardware Installation Guide" which will be enclosed with the system. If this unit has been ordered separately, we assume here that you already have a flexiBox system with a Flexipanel and that the flexiBox has at least two spare slots above each other for the EM-4 card. If this system is part of a **playout**, please refer to the **playout** user guide for an example of the use of the EM-4.

2.2 Installing the EM-4 into a flexiBox

To install the EM-4 into a flexiBox it is desirable (but not necessary) to power down the flexiBox. Follow these instructions.

On the rear of the flexiBox are 6 slots for Products. Remove any pair of spare blanking plates one above another. There are 2 off M2.5 Screws, which require unfastening for each blanking plate.

Slide the Product PCB into the spare slots and firmly push it "home".

Use the four thumbscrews to fasten the unit in place. Take care that the ribbon cable for the upper circuit board stays attached to the lower board.

Now refer to the "GeNETics User Guide". If your system consists of a single flexiBox with a single flexiPanel then refer to the section titled "flexiPanel Auto Set-up". If your system is part of a network with more than one flexiPanel then refer to the section titled "flexiPanel Manual Set-up". This will guide you through acquiring your product as a device on the flexiPanel.

2.3 Connecting Video to an EM-4

The connections on an EM-4 are shown below, video in and out are shown and the table gives the pin numbers on the 15W D type.

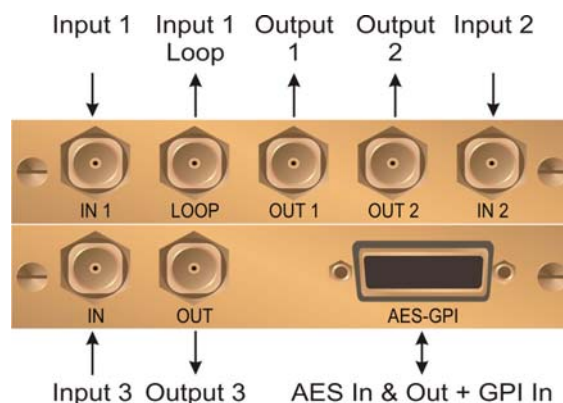

Pin Number	Function
1	AES 1 Input+ (EMBEDS ON OUTPUT 1)
2	AES 1 Input- (EMBEDS ON OUTPUT 1)
3	AES 2 Input+ (EMBEDS ON OUTPUT 2)
4	AES 2 Input- (EMBEDS ON OUTPUT 2)
5	AES Output + (AES FROM INPUT 3)
6	AES Output - (AES FROM INPUT 3)
7	AES Output + (AES FROM INPUT 3)
8	AES Output - (AES FROM INPUT 3)
9	AES Output + (AES FROM INPUT 3)
10	AES Output - (AES FROM INPUT 3)
11	AES Output + (AES FROM INPUT 3)
12	AES Output - (AES FROM INPUT 3)
13	GPI #1 (not used)
14	GPI #2 (not used)
15	GND

Figure 2-1 Connections for the EM-4

2.4 Connecting Panels to the EM-4

The EM-4 may be operated using a FP-9 Flexipanel locally mounted. For a more operational environment the EM-4 may be supplied with a desk mounting FP-10 unit. For detailed information on connecting remote panels refer to the section “Connection of Remote Panels to a flexiBox” in the geNETics Hardware Installation Guide.

Below is shown a typical system consisting of an EM-4 in a flexiBox controlled by an FP-10 and a VP-10.

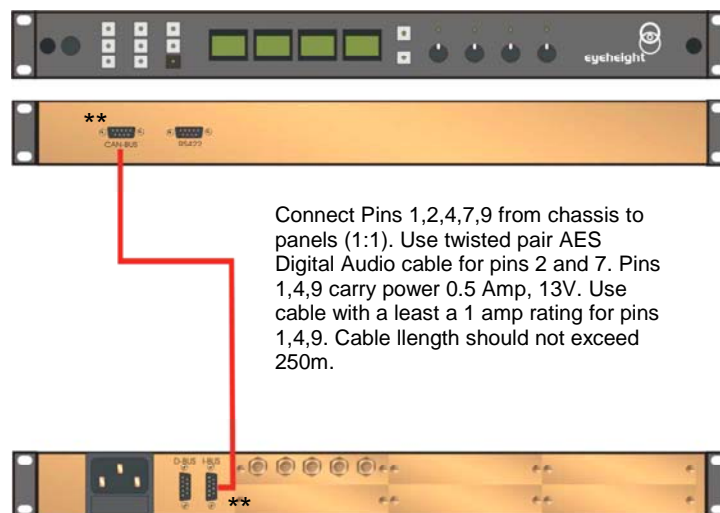

Connect Pins 1,2,4,7,9 from chassis to panels (1:1). Use twisted pair AES Digital Audio cable for pins 2 and 7. Pins 1,4,9 carry power 0.5 Amp, 13V. Use cable with a least a 1 amp rating for pins 1,4,9. Cable llength should not exceed 250m.

I-Bus pins 2 & 7

** The I-BUS Network requires terminating with 100 Ohms at each extreme end of the network. Ensure that this is done either by an external 100 ohm resistor OR ONE Panel/Product at each end has the termination set. See the "Genetics User Guide" Under the sections "Flexipanel Power/I-BUS Jumpers". For the 4RU Panels see "4RU Panel (FP-10) Jumpers for I-BUS" and "4RU Panel (VP-10, SW-10, AP-10) Jumpers for I-BUS". Alternatively The termination can be set on a Product (ie the AD-2/AD-2E module). Information about this is given in this manual.

Figure 2-2 I-Bus Connections and Termination

N.B. From 1/10/02 Eyeheight introduced a change in the flexiBox Chassis. Most versions now have two 9 way connectors on the rear labelled "I-Bus" and "D-Bus". The "I-Bus" connector is the same as the previously labelled "Can-B" connector. Although a maxiBox is shown in this diagram the same arrangement applies for a flexiBox chassis.

Please also note that this shows a T-Bar module (VP-10) the connections are the same for the AP-10 fader module.

3 Operation

3.1 Manual control of the EM-4

Manual Control of the EM-4 is done using one or more of the following control surfaces:

- The 1RU FP-9 flexiPanel.
- The FP10 Desk mounting panel
- The FP-9 and the FP-10 have identical manual control systems. (The FP-10 is simply a desktop version of the FP-9). The AP-10 brings further functionality to the unit in the manual fader transitions.

The EM-4 is, as are all genetics modules, controlled using a set of MENUS. Each of these menus contains up to 3 parameters that are adjusted using the rotary digipots. The Menus define all of the adjustable operational parameters in the EM-4. Pressing the rotary digipots brings the parameter to its default value. Device selection is done using the device select switches which, when pressed, will offer the name of the device in the LCD Window. Modules can be acquired and then de-acquired using the set-up switch. For a full description of the operation philosophy of the geNETics system refer to the “geNETics User Guide” (section “Operation of the flexiPanel”)

A full list of the Menus and their functions are given in section 3 of this chapter.

3.2 Automation Control of the EM-4

Automation of the geNETics products is achieved via an RS422 port.** This port is marked RS422 on the rear of a flexiBox. For the port to work a flexiPanel MUST be connected locally on the front of the flexiBox.

Automation control of the EM-4 can be done using two protocol methods:

- geNETics Automation Protocol.
- PresTX Automation Protocol.

Genetics protocol is described in detail in the “GeNETics User Guide” section titled “Automation Protocol on the geNETics Platform”. The menu list in section 3 of this chapter contains the data information for the protocol.

PresTX Automation Protocol is used only for the PresTX Presentation Mixer and channel branding system. In this case an AU-2 Automation card is also required. Refer to the PresTX Product manual

**On most flexiBoxes later than 1/10/02 the RS422 port has been replaced by a “D-Bus” Port. The D-Bus port is for High Speed data transfer and is not used for serial control. In order to achieve serial control of any products on an I-Bus network Eyeheight Ltd have developed a RS232→I-bus converter “dongle”, (DG-9) which enables greater flexibility of products on the I-Bus network whilst using the same protocols as the RS422 port. Please refer to the “User guide for the

DG-9 eyeheight dongle and set-up software.

3.3 Operational Menus for the EM-4

Menu 00-03: Top level controls

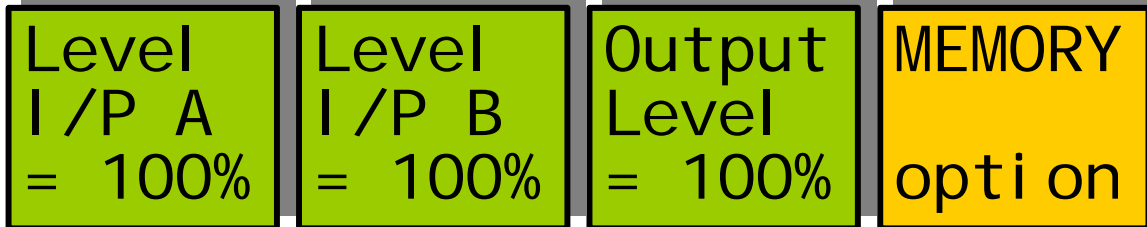

Menu Num.	Heading	Automation	Function
0	Level I/P A (0 to 800%)	0 to 8191 Default is 1024 (=100%)	This option adjusts the level of the A input.
1	Level I/P B (0 to 800%)	0 to 8191 Default is 1024 (=100%)	This option adjusts the level of the A input.
2	Output Level (0 to 400%)	0 to 8191 Default is 2048 (=100%)	This option adjusts the output level.
3	Memory	N/A	Pressing this button will select the memory control menus.

Menu 04-07: Memory Controls

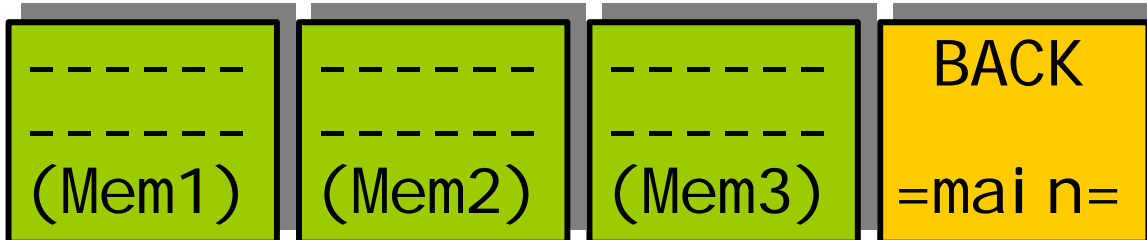

Menu Num.	Heading	Automation	Function
4	MEM1	1=Recall	Pressing this will recall Memory number 1. User Names can be programmed in to the memories using a keyboard.

			See “geNETics User guide”, section “Giving product Memories names”
5	MEM2	1=Recall	Pressing this will recall Memory number 2.
6	MEM3	1=Recall	Pressing this will recall Memory number 3.
7	Back	N/A	Pressing this button will take the user back to the main menu

Menu 08-11: Memory Controls

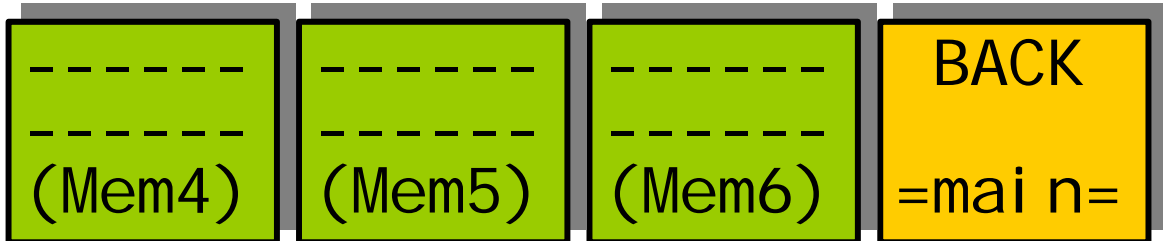

Menu Num.	Heading	Automation	Function
8	MEM4	1=Recall	Pressing this will recall Memory number 4.
9	MEM5	1=Recall	Pressing this will recall Memory number 5.
10	MEM6	1=Recall	Pressing this will recall Memory number 6.
11	Back	N/A	Pressing this button will take the user back to the main menu

Menu 12-15: Memory Controls

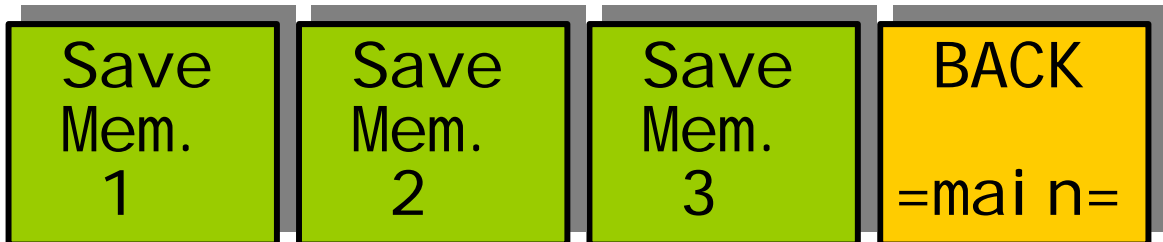

Menu Num.	Heading	Automation	Function
12	Save Mem. 1	1= Save	Pressing this will Save Memory number 1.
13	Save Mem. 2	1= Save	Pressing this will Save Memory number 2.
14	Save Mem. 3	1= Save	Pressing this will Save Memory number 3.
15	Back	N/A	Pressing this button will take the user back to the main menu

Menu 16-19: Memory Controls



Menu Num.	Heading	Automation	Function
16	Save Mem. 4	1= Save	Pressing this will Save Memory number 4.
17	Save Mem. 5	1= Save	Pressing this will Save Memory number 5.
18	Save Mem. 6	1= Save	Pressing this will Save Memory number 6.
19	Back	N/A	Pressing this button will take the user back to the main menu

Menu 20-23: Software version

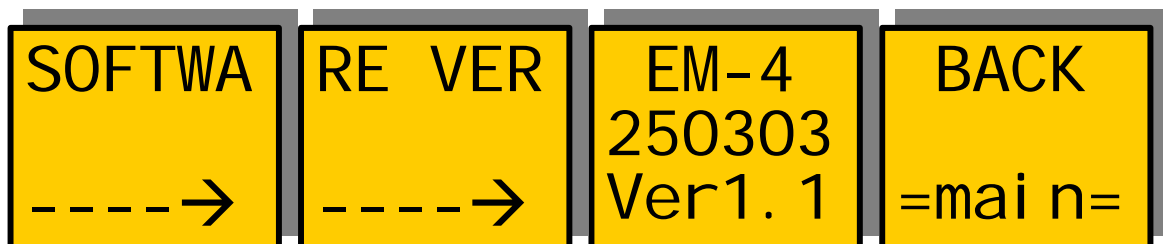

Menu Num.	Heading	Automation	Function
20		N/A	Info
21		N/A	Info
22	EM-4 230103 Ver2.5	N/A	Info, the top line is product identifier, the middle is the date the software was last changed, and the last line is the software version.
23	BACK	N/A	Pressing this button will take the user back to the main menu

Menu 24-27: Top Level Controls



Menu Num.	Heading	Automation	Function
24	Set As Pow On Memory	1=save	Pressing this will save the current set up as the power on default.
25	Recall Pow On Memory	1=Recall	Pressing this will recall the power on default settings.
26	TOTAL RESET	1=Reset	Pressing this will reset the system.
27	BACK	N/A	Pressing this button will take the user back to the main menu

4 Technical Appendix

4.1 Technical Specification for the EM-4

Number of Inputs	3
Type of Inputs	270Mbit Serial Digital Video Inputs 75 Ohm, comprising of 2 inputs for embedders and 1 input for de-embedder. 2 AES Audio Inputs (to embed)
Line Length	At least 200 Meters of PSF1/3 (Typically 275 Meters)
Number of Outputs	4 Output BNC's , 2 SDI outputs for embedders, 1 SDI output for de-embedder, and a loop for input 1. 4 off AES audio output streams (two audio streams with two outputs per stream. Output of de-embedder)
Type Of Outputs	270Mbit Serial Digital Video Outputs, 75 Ohm, 800mV
Total Number Of BNC Connections	7, consisting of 3 Inputs, 4 outputs.
SDI Output Jitter	The system will add less than 0.2UI to the input Jitter. (This is only guaranteed on issue 2 or later cards)
Current Consumption	<800mA at +5V
Size	215mm by 100mm

4.2 Jumpering the I-BUS (CAN-BUS) Termination

The I-BUS Network is the "control system" under which all Products and Panels are networked together. Under certain circumstances it is necessary to terminate the network. This can be done on a Panel or a "Product". To terminate this product, locate J6 on the EM-4 Processor Card supplied which is between U1 (The large square "chip") and the Edge connector. (This is on the half of the card labelled "CHP-100 Spartan2 Processor"). Jumper this with a 2mm link.

J6

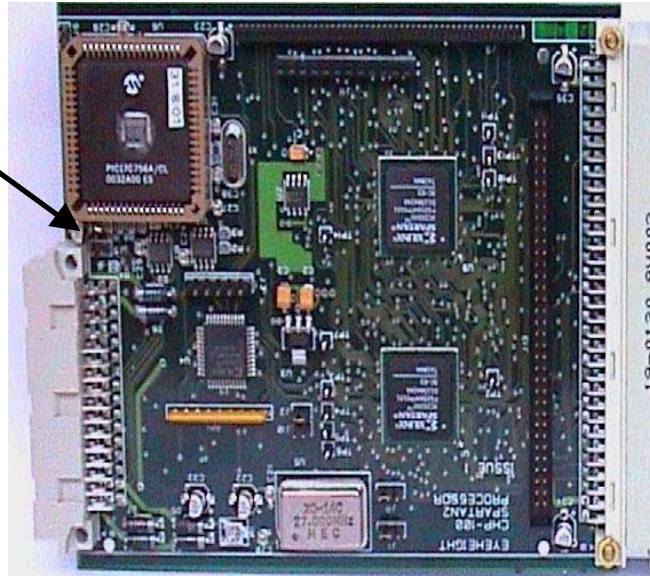
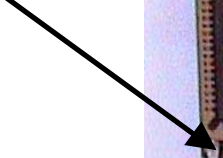

Figure 4-1 Location Of I-Bus Termination Link

4.3 CHP-100 SDI-TC-GPI Card

4.3.1 Jumper Links on the Timecode and GPI I/O card

The AES output has a number of jumper links, which effect the formatting of the AES, output data.

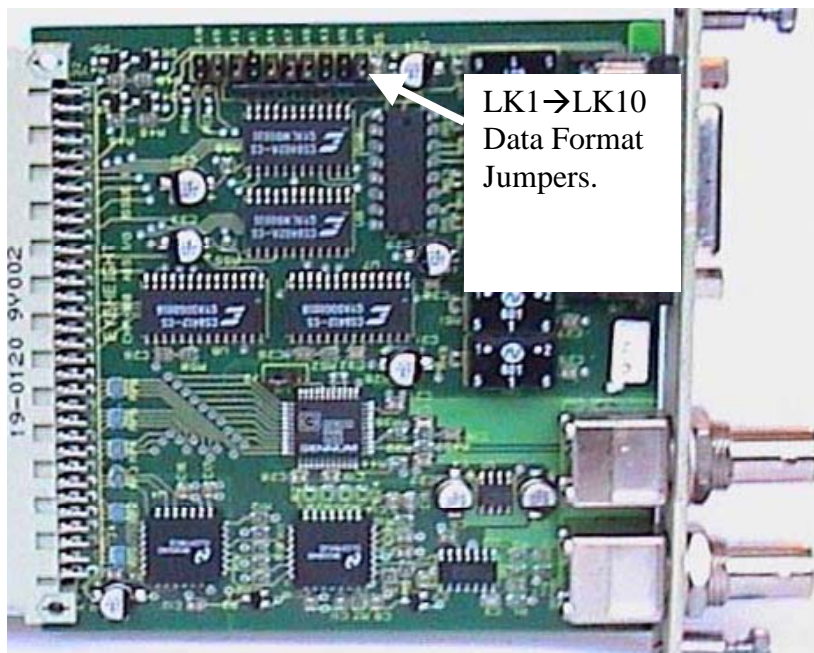

Figure 4-2 jumpers on the EM-4 I/O card

Link No.	Function of LK1→LK10 Links	Standard
10	Emphasis1, combined with Emphasis0 sets the Equalisation data on the channel status bits	No Link
9	Emphasis0, combined with Emphasis1 sets the Equalisation data on the channel status bits	Link
2	Stereo mode set in Channel Status bits. (Link to set)	Link
1	User Bit set in Channel Status bits. (Link to clear)	Link
4	Diagnostic MUST BE LINKED!!	Link
7	Validity Bit set in Channel Status bits. (Link to clear)	No Link
8	Sampling Freq1. combined with Sampling Freq0 sets the Sampling Frequency data on the channel status bits.	No Link
3	Non-Audio Bit set in Channel Status bits. (Link to set)	No Link
6	Professional Mode Bit set in Channel Status bits. (Link to set)	Link
5	Sampling Freq0. combined with Sampling Freq1 sets the Sampling Frequency data on the channel status bits.	Link

Emphasis0	Emphasis1	Function
No Link	No Link	Undefined Emphasis
Link	No Link	No Emphasis
No Link	Link	50/15uS Emphasis
Link	Link	CCITT J17 Emphasis

Sampling Freq0	Sampling Freq1	Function
No Link	No Link	32.0K Sampling
Link	No Link	48.0K Sampling
No Link	Link	44.1K Sampling
Link	Link	Sampling Freq Not Indicated.