

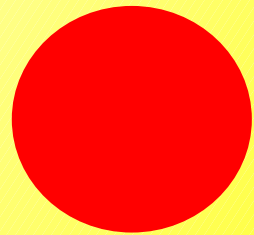

GeNETics Product Information

Hardware Installation Guide

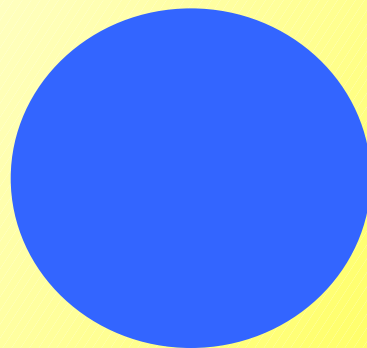

Revision 2 - 09 September 2002

Table Of Contents:

SCOPE OF THIS GUIDE	3
UNPACKING A FLEXIBOX SYSTEM	3
RECEIVING A FLEXI-BOX "SYSTEM"	3
INSTALLATION REQUIREMENTS OF A FLEXIBOX SYSTEM	3
ELECTRICAL REQUIREMENTS OF A FLEXIBOX SYSTEM	4
SIGNAL CONNECTIONS OF A FLEXIBOX SYSTEM.....	4
RECEIVING A MINI-BOX SYSTEM.....	5
INSTALLATION REQUIREMENTS OF A MINIBOX SYSTEM	5
ELECTRICAL REQUIREMENTS OF A MINIBOX SYSTEM.....	5
SIGNAL CONNECTIONS OF A MINIBOX SYSTEM	6
OPERATION OF A MINIBOX SYSTEM	6
PROGRAMMING A MINIBOX USING A FLEXIPANEL.....	7
USING A MINIBOX WITH A FLEXIPANEL	8
USING A MINIBOX WITH EXTERNALLY PROVIDED SWITCHES.....	8
FLEXIPANEL CONNECTION PIN LIST	9
CONNECTION OF REMOTE PANELS TO A FLEXIBOX.....	10
LOCAL FLEXIPANEL POWER SUPPLY REQUIREMENTS.....	11
CONNECTION OF 1 REMOTE PANEL TO A FLEXIBOX.....	11
CONNECTION OF 2 REMOTE PANELS TO A FLEXIBOX	12
CONNECTION OF MANY REMOTE PANELS TO MANY FLEXIBOXES	13
DISASSEMBLY/ASSEMBLY A FLEXIPANEL FP-9 AND COVER RR-9	13
REMOVING A FLEXIPANEL FP-9 FROM A FLEXIBOX FB-9.....	13
ADDING/REMOVING A "HOT SWAP" REDUNDANT PSU	14
CHANGING THE INTERNAL FLEXIBOX FUSES	15
CHANGING THE INTERNAL FLEXIBOX FUSES	15
USING THE PSU FAIL TALLY FOR REMOTE POWER FAIL ALARM	16

Scope Of this Guide

This guide gives practical information in setting up GeNETics system. It covers the "Hands On" Hardware details and will refer frequently to sections in the "GeNETics User Guide" or the individual "Product" Manuals which will give more detail on specific points.

Unpacking a Flexibox system

When goods are received from Eyeheight Ltd, please check the packing note to ensure that all the goods are contained inside. It is advisable not to use long bladed knives to open any packing case as this may inadvertently damage any goods within.

Receiving a Flexi-Box "System"

In many cases the user will be in receipt of a complete Flexibox System, for example:

1. An FB-9 Flexibox
2. An FP-9 Flexipanel
3. An FP-10 Desk mounting panel 4RU with a VP-10 T-BAR Panel
4. One or more Products to fit inside the chassis (1). (e.g. MW-2,BL-1....).

This Flexibox System will be set up in the factory and be fully assembled in a standard configuration that should suit most users.

Installation Requirements of a Flexibox System

The Flexi-Box is normally mounted in a standard 19 inch racking bay. Mounting is in no way unusual. There some points, however, worth mentioning.

1. The Flexi-Box relies on forced air (fan) ventilation from side to side. It is important to allow at least 1cm on the left (looking from the front) for the ventilation slots. It is also important to leave at least 4cm on the right (looking from the front) for the fan to blow out the warm air.
2. The unit requires 4 x M5 rack bolts to secure the unit at the front. It is necessary also that the unit be given support at the rear. Generic 1RU sliding mounts, or rear-mounting brackets can give this support. These are available normally from the manufacturers of the 19" rack bays.

3. The units should be run in an air-conditioned technical area with an ambient temperature no greater than 25 C.
4. The Electrical supply should be a "Clean" technical mains supply free from heavy machinery that might introduce mains spikes.

Electrical Requirements of a Flexibox system

A Flexibox system will use less than 50 Watts of power from an electrical supply. The power supplies are "Wide Range" and will operate from a steady 100→250 Volts AC 50 or 60Hz. A clean technical mains is required to ensure "Glitch Free" operation.

The unit has TWO IEC Mains inlets. For users who have the "**Redundant Power Supply**" option (PSU-2) it is necessary that both of these IEC Inlets are wired to independent mains supplies. For users who have not specified this option only use the IEC Inlet labelled "PSU-1".

The Flexibox is currently fitted with a Live and Neutral Twin Fuse, which is detachable underneath the IEC Inlet. The fuses should only be replaced with "Slow-Blow 1 Amp 20mm type". Should the user request a single fuse system, please call Eyeheight Ltd, as this can be accommodated.

Signal Connections of a Flexibox system

Please refer to the individual "Product Manual" for the individual signal (Video, Audio, Timecode etc) connections.

Unpacking a Mini-Box System

When goods are received from Eyeheight Ltd, please check the packing note to ensure that all the goods are contained inside. It is advisable not to use long bladed knives to open any packing case as this may inadvertently damage any goods within.

Receiving a Mini-Box System

The Minibox System is always shipped assembled and configured for use, It will consist of:

1. An MB-9 Minibox
2. One Product to fit inside the chassis (1). (e.g. MW-2,BL-1....).
3. An External "Power Block" which comes as part of the MB-9

The Mini-Box System is NOT user-upgradable. It is purchased as a complete system and Service at Eyeheight Ltd must do any changes or modifications.

Installation Requirements of a Minibox System

The Mini-Box is a "Desktop" unit and should be placed on a convenient surface.

1. The Flexi-Box relies on conduction from the casing walls of the unit to cool it. It is important to free airflow around the unit.
2. The units should be run in an area with an ambient temperature no greater than 25 C.
3. The Electrical supply should be a "Clean" technical mains supply free from heavy machinery that might introduce mains spikes.

Electrical Requirements of a Minibox system

A Minibox system is run via a 7.5 Volt, 1 Amp unregulated "Power Block", which is supplied with the unit. This will use less than 10 Watts of power from an electrical supply. The Power Block supplied will operate from a steady 220→250 Volts AC 50Hz and requires a free flow of air around it for cooling. 115V Power Blocks can also be supplied if requested. A clean technical mains is required to ensure "Glitch Free" operation.

Signal Connections of a Minibox system

Please refer to the individual "Product Manual" for the individual signal (Video, Audio, Timecode etc) connections.

Operation of a Minibox system

The Minibox System is a combined desktop box with a small front panel. Limited operation of the product is available using the five switches on the Front Panel. The Front panel Switches can be programmed by the user, using a Flexipanel, to perform a particular function. This is done by programming the "User Memories" of this particular product. Once this is done you can access Memories 1→4 by pressing buttons 1→4 on the minibox, and access Memories 5→8 by pressing buttons 1→4 while keeping the "Fn" button held down.

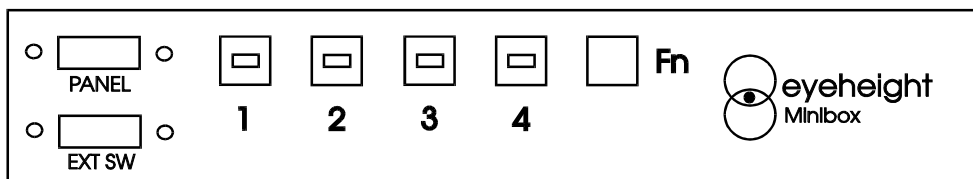

Front Panel

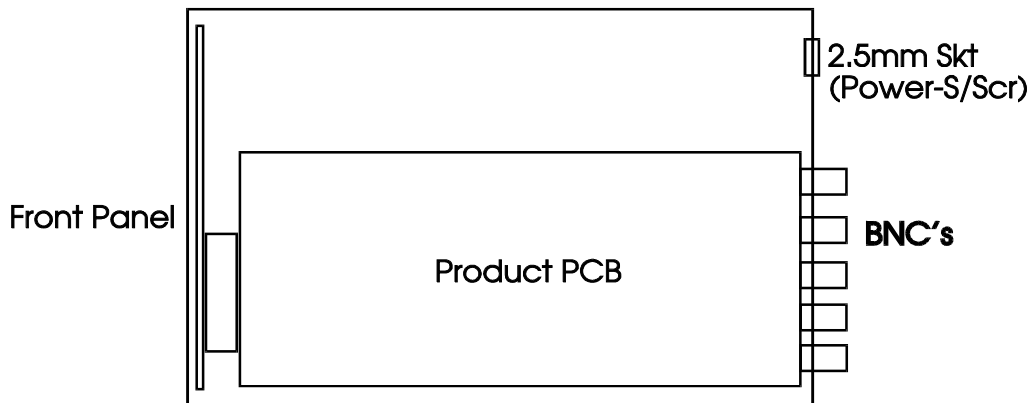

Top View Of Minibox Showing Internal PCB

Programming a Minibox using a Flexipanel

The Minibox Front Panel will either come pre-programmed to the customers specifications or it can be programmed by the customer using a Flexipanel. In order to do this you will need the following items:

1. An FP-9 Flexipanel with an RR-9 rear cover.
2. A PS-2 Keyboard (KB-9).
3. A lead with 9Way D-type Male connectors at either end. The lead must be less than 1 Meter long and have 1:1 connections on all 9 conductors.

It is now necessary to set the Flexipanel Power to Local. This is done using Jumper links. Please refer to the "Genetics User Guide" Under the section "Flexipanel Power/I-BUS Jumpers".

Now follow the following steps:

1. Connect the Flexipanel to the Minibox connector labelled "PANEL" using the 9 way lead above. Switch the power on to the Minibox by connecting the "Power Block" dc connector to the rear of the minibox (Labelled 7.5V dc) and then plugging the "Power Block" into the Mains. The Flexipanel should light up with a start message.
2. Plug the PS-2 Keyboard into the Flexipanel K/B socket.
3. Type "F9" to enter Text Messaging Mode. Then type "F:fb" followed by <RETURN>. This is to give the panel a "First Birthday" or "Reset" before continuing.
4. Power down the box, wait 5 seconds and apply power again.
5. The Panel should enter set-up automatically. Now follow the instructions to perform an "Auto Set-up" as described in the "GeNETics User Guide" section titled "Flexipanel Auto Set-up". Now exit set-up by pressing the set-up button. The product should now display the first set of menus applicable to this particular product.
6. The next step is to program the memories of the Product to the users desired set-ups. Please refer to the "Product" Manual to do this.
7. Disconnect the Flexipanel. The memories should now be accessible on the minibox front panel.

Using a Minibox with a Flexipanel

The Product within the minibox may be controlled using a Flexipanel instead of the minibox front panel. Simply refer to the previous section "Programming a Minibox using a Flexipanel" which gives a step by step guide to configuring the system in this manor. (However clearly ignore Step 7 where the panel is disconnected at the end, and Step 6, programming the memories is also not necessary)

Using a Minibox with Externally Provided Switches

The minibox has a connector labelled "EXT SW". This allows the user to provide their own switch panel as an alternative to the one provided on the front panel. The connections are shown below.

Pin No.	Function
1	Switch No.1
2	Switch No.2
3	Switch No.3
4	Switch No.4
5	Ground
6	LED No.1
7	LED No.2
8	LED No.3
9	LED No.4

"EXT SW" External Switch Connection details

Switch contact closure is momentary and requires closure of pins 1,2,3 or 4 to Ground. The LED Connection must be as follows:

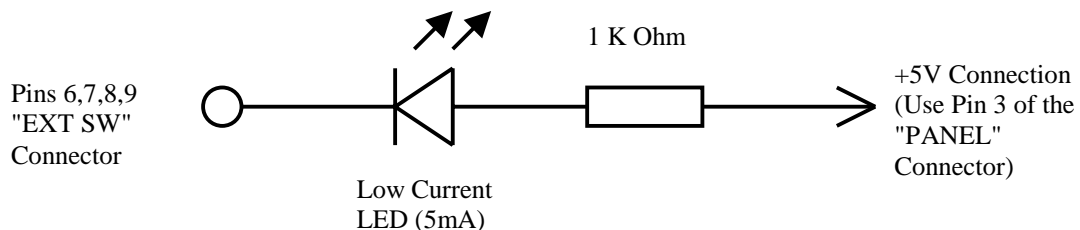

Minibox to Flexipanel Connection Pin List

The Flexipanel Connection Pin list for the **Minibox** connector is given below:

Pin 1	Ground 0V
Pin 2	I-Bus-
Pin 3	+5V Local regulated Supply (From Mini-box) 0.5Amp*
Pin 4	Not Used
Pin 5	Ground 0V
Pin 6	+5V Local regulated Supply (From Mini-box) 0.5Amp*
Pin 7	I-Bus+
Pin 8	Not Used
Pin 9	Not Used

Connection of Remote Panels to a Flexibox

A Flexibox (FB-9) can have remote panels connected to it as well as having one Local panel connected on the Front. A Flexipanel when used remotely consists of two items:

1. A Flexipanel (FP-9)
2. A rear "cover" with I-BUS and RS422 connector (RR-9)

Other Panel options are as follows:

1. A Desk mounting 4RU panel, (FP-10)
2. A Desk mounting 4RU Video T-BAR and switch panel (VP-10)
3. A Desk mounting 4RU Dual Audio Fader Panel (AP-10)
4. A Desk mounting 4RU Auxiliary Switch Panel (SW-10)

There is a restriction of a maximum of two FP9 or FP-10 panels that can be powered remotely from a single Flexibox as well as up to 5 VP-10 or AP-10 or SW-10 panels. Further panels will require a user supplied remote Power supply.

PLEASE NOTE: 2 Amp Fuses, which are located INTERNALLY in the Flexibox, protect the power supply to the Remote Flexipanel. It is not possible to change these fuses without powering down the box. It is recommended that for ON-AIR situations the installation be done with Local Power supplies for the flexipanel.

The I-Bus network connection is described in detail in the "GeNETics User Guide" under the section "Physical connection of the I-Bus Network".

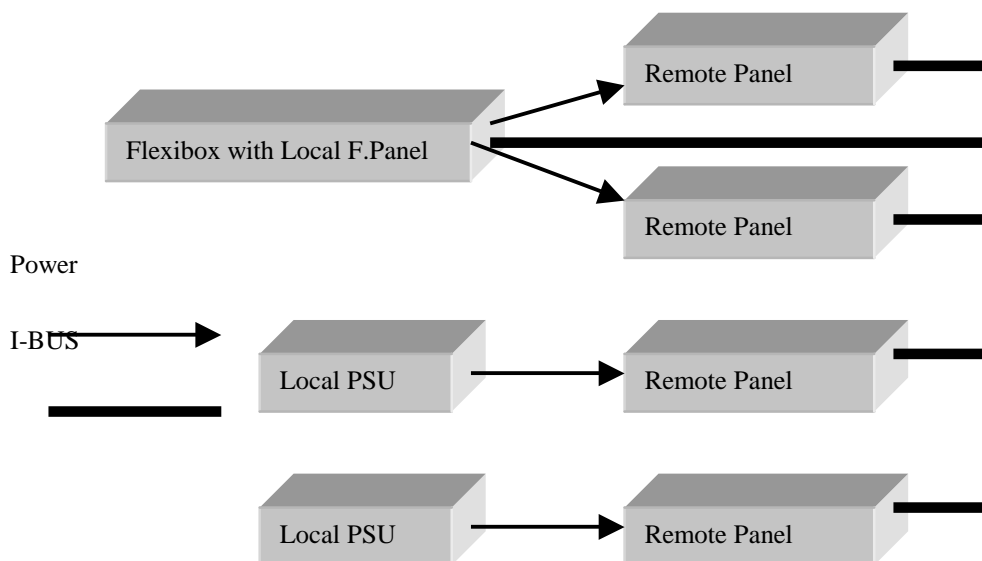

Typical Power Configuration for a Flexibox/Panel System.

The remote connection is the 9W D-type female connector labelled "CAN-BUS" or "I-BUS" on both the Flexipanel and the Flexibox. This connector has both remote power and the 2 wire I-BUS Network. Please refer to the "GeNETics User Guide" under the section "I-BUS (CAN-BUS) Connector Pinouts" for connection information.

Local Flexipanel Power Supply Requirements

The Local Power Supply for a flexipanel should have a specification as follows:

Supply Type	Unregulated DC
Supply Current	0.5Amp minimum
Supply Voltage	8V→12V

For a local Power supply connect the Power to pins 4 and 9 (+) and Ground to pin 1 (-) on the CAN-BUS/I-BUS Connector on the RR-9 (rear cover of Flexipanel).

Connection of 1 Remote panel to a Flexibox

In order to connect 1 remote panel to a flexibox simply wire the system together as follows:

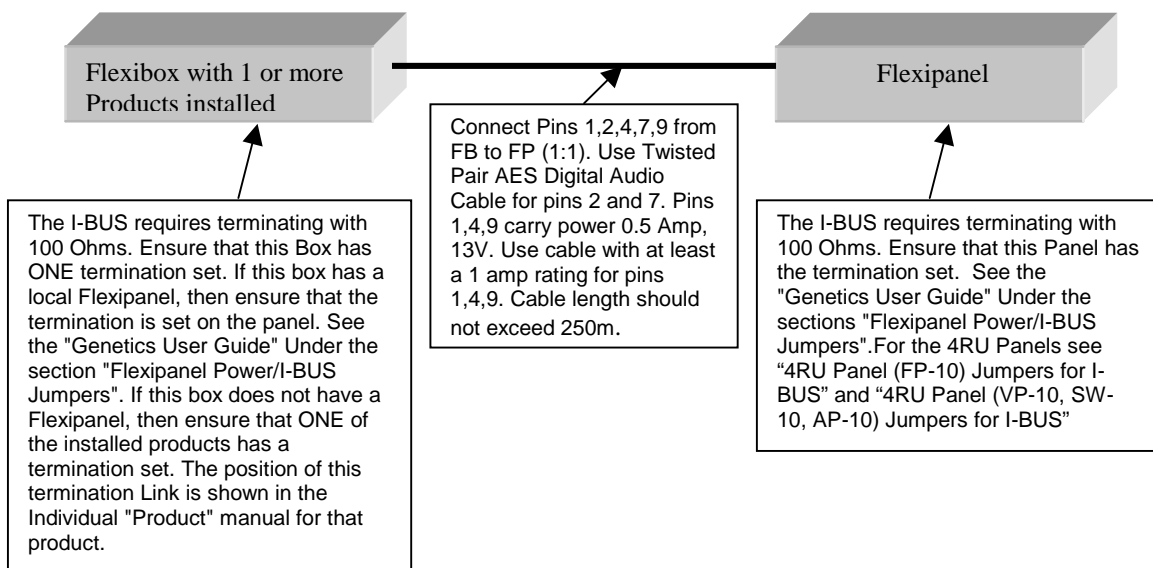

Connection of 2 Remote panels to a Flexibox

In order to connect 2 remote panels to a flexibox simply wire the system together as follows:

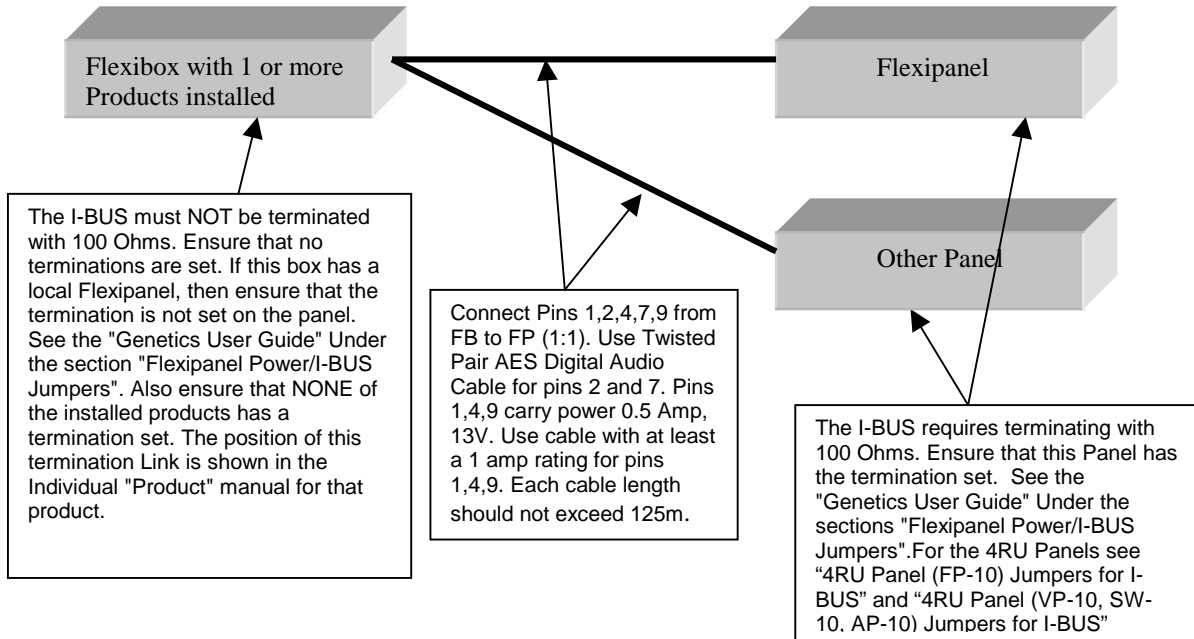

Flexibox to Flexipanel Connection Pin List

Pin 1	Ground 0V
Pin 2	I-Bus-
Pin 3	+5V Local regulated Supply (From Flexi-box) 0.5 Amp.
Pin 4	Remote Supply (From Flexi-box) 13V 1 Amp
Pin 5	Ground 0V
Pin 6	+5V Local regulated Supply (From Flexi-box) 0.5 Amp.
Pin 7	I-Bus+
Pin 8	PSU Fail Tally.
Pin 9	Remote Supply (From Flexi-box). 13V 1 Amp

Connection of Many Remote panels to many Flexiboxes

For a system with many Remote Panels and Flexiboxes, please refer to the "Genetics User Guide" under the section "Physical connection of the I-Bus Network". This explains the principles of larger systems and the best way to connect a network together.

Disassembly/Assembly a Flexipanel FP-9 and Cover RR-9

Disassembly of the FP-9 and RR-9 is as follows:

1. Ensure that any cables are removed from the rear connectors.
2. Locate the thumbscrews at each end of the Flexipanel (FP-9) and unscrew them.
3. Slowly pull forward the Flexi-panel away from the Rear cover. As you do this two connectors with ribbon cables will be seen.
4. Remove the connectors from the Flexipanel PCB noting the connector orientation and position for re-assembly.

Re-assembly is a reverse of the above sequence.

Removing a Flexipanel FP-9 from a Flexibox FB-9

Disassembly of the FP-9 and FB-9 is as follows:

1. If possible Power down the Flexibox. If this is not possible please proceed cautiously with regards to removing the Flexipanel PCB from the Flexibox.
2. Locate the thumbscrews at each end of the Flexipanel (FP-9) and unscrew them.
3. Slowly pull forward the Flexi-panel away from the Flexibox (If the power is on, be careful not to hit the rear of the Flexipanel PCB against the chassis). As you do this two connectors with ribbon cables will be seen.
4. Remove the connectors from the Flexipanel PCB noting the connector orientation and position for re-assembly.
5. If this Flexipanel is to be removed permanently, it is ESSENTIAL that an FF-9 blank front panel is purchase from Eyeheight Ltd in place of the Flexipanel. This is to facilitate correct airflow and to comply with EMC and safety regulations.

Re-assembly is a reverse of the above sequence.

Adding/Removing a "Hot Swap" redundant PSU

Adding a "Hot Swap" PSU (PSU-2) provides a redundant PSU to the Flexibox.

Below shows the rear of a Flexibox. The IEC labelled " PL1 AC IN " is the mains supply for a system provided with a single PSU-2.

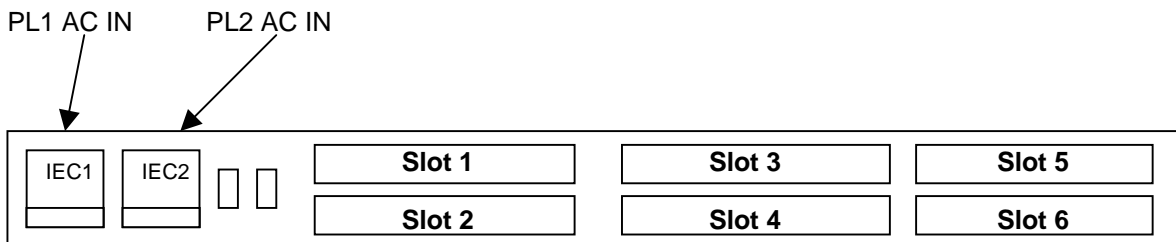

Rear of Box, showing the Position of the two IEC Mains connectors

The diagram below shows the front of a Flexibox with the Flexipanel or FF-9 Blank front panel removed. This shows the positions of the PSU-2 units along with their respective rear connections.

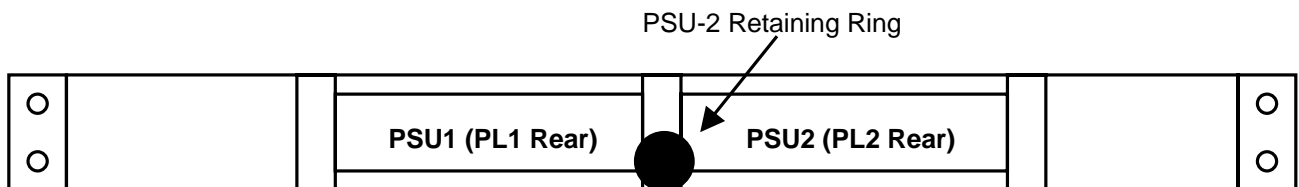

Front of Box, showing the Position of the two PSU-2 Power supplies.

To add/remove/exchange a hot swap power supply. Do the following:

1. Follow the instructions in the section "Removing a Flexipanel FP-9 from a Flexibox FB-9" in this guide. Should the system have a blank "FF-9" panel on the front, this is simply removed using the two thumbscrews.
2. Remove the PSU-2 Retaining ring shown above by unscrewing the M2.5 screw in the centre of it.
3. Add/remove/exchange the relevant PSU-2.
4. Re-assemble the above.

Each PSU-2 from Eyeheight Ltd will come fully aligned and tested. It will not need any adjustment. All PSU-2 units work from 100V to 250V AC without adjustment.

Changing the Internal Flexibox Fuses

There are TWO internal fuses within the Flexi-box. These are low voltage fuses, which protect the Flexibox from possible inadvertent Short Circuits on the Power Supplied externally for The Flexipanel. (13.5V dc). Should these fail it is necessary to power down the Flexibox. For ON-AIR situations it is advised that the user does not use the internal PSU because panel/wiring failure will cause these fuses to blow and for ON-AIR situations powering down the Flexibox to replace these fuses is not usually a viable option.

To change the fuses in the flexibox, do the following.

1. Power down the flexibox and remove all Video/Audio/Signal cables from the rear of the unit.
2. Remove the unit and place onto a workbench.
3. Remove the Top Lid of the unit by unscrewing the 14xM2.5 screws.
4. Locate the fuses, which are easily seen in plastic covers close to the Extractor Fan.
5. Replace the fuse(es) with 2 Amp Slow blow types.
6. Re-assemble the unit in above reverse order.

Changing the External Fuses on the Flexibox

The fuses are located on the rear of the Flexibox underneath the respective IEC mains inlet plugs. The current unit has a live and neutral fuse. Single (Live) fuse units can be provided by request to Eyeheight Ltd.

To replace the external fuses follow this procedure, which can be performed while the redundant PSU-2 is still powered:

1. Remove the IEC socket+lead, which is connected to the "failed" inlet.
2. Remove the fuse carrier for the above IEC inlet.
3. Replace one or both faulty fuses with 2 Amp slow blow fuses rated at 250V.
4. Replace the fuse carrier.
5. Replace the IEC socket+lead power.

PLEASE NOTE: If the fuse has blown it is probable that the associated PSU-2 is faulty and we recommend replacing it before power is re-applied.

Using the PSU Fail Tally for remote Power Fail Alarm

The following is the recommended way to provide a tally from the Flexibox for an alarm failure:

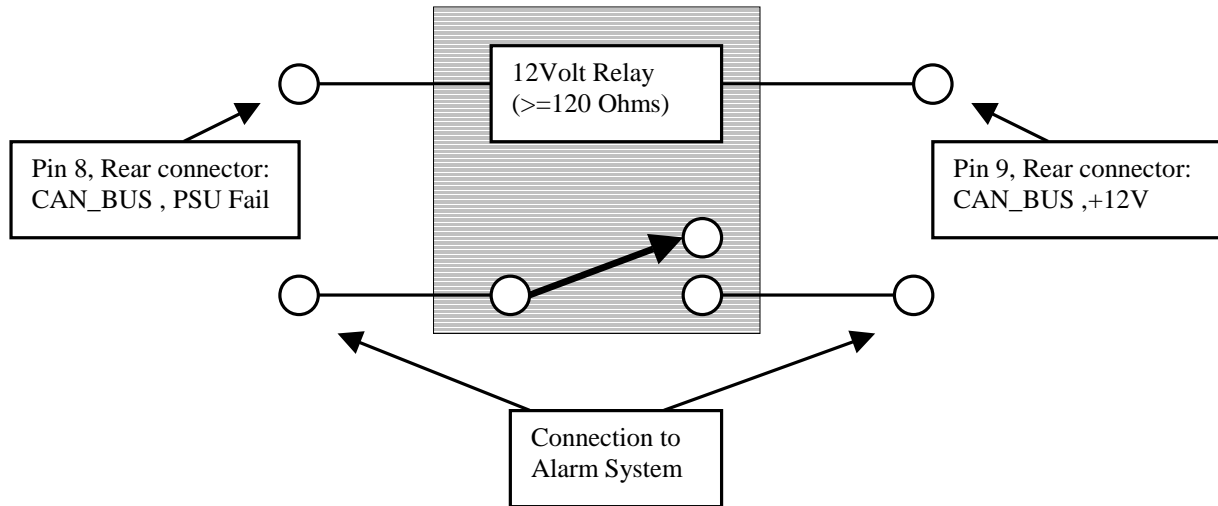

Upon a PSU Fail (Either Main or redundant +5V, -5V or +13V) pin8 becomes a "Ground", 0V connection. While PSU's are OK this pin is "Open". Please note that with NO PSU Installed this indicates PSU's are OK !! Which is (Technically) incorrect. A 12V relay (100mA) can be connected from pin 8 to pin 9 to indicate PSU Fail.