

Operations Manual for the ADPm 1000 Auxiliary Data Processor



UNI-System

25/07/2001/V6.1 Software

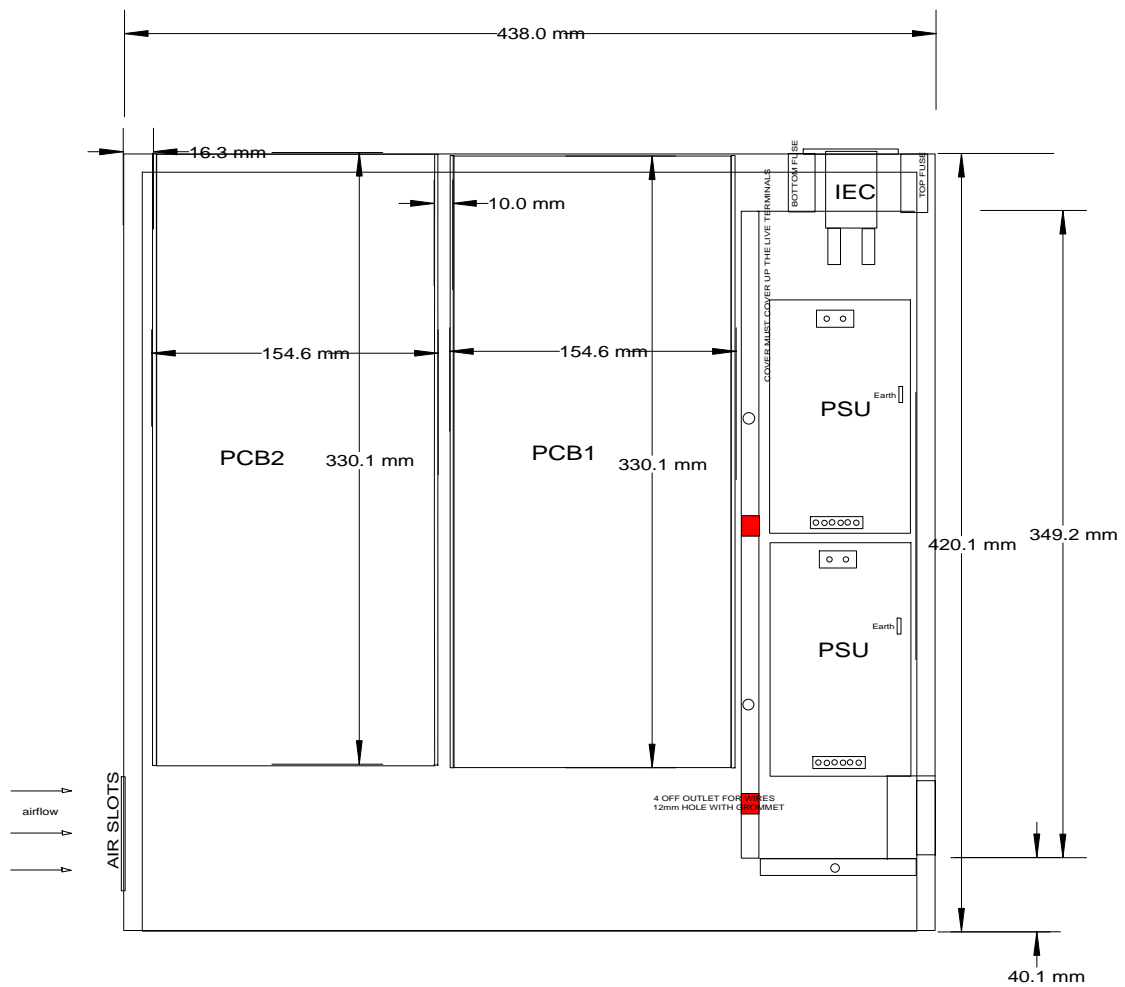

Table of Contents

Page 3	Overall Specification
Page 4,5	Technical Specification
Page 6,7,8	Overall ADPm-1000 System
Page 9	Overall ADPm-1000 Block Diagram
Page 10	Explanation of the Eyeheight Uni-System Generic Menu System.
Page 10,11	UNI-panel Set-up Features
Page 12-15	ADPm-1000 Soft Menu List.
Page 16,17	ADPm-1000 Button Push Functions
Page 18	Assembly of the ADPm-1000 into a UNI-Box
Page 19	Rear Panel Connections
Page 20	User Jumpers on the ADPm-1000 PCB
Page 21	GPI Outputs as in-line mapping
Page 21	Input GPI Mappings.
Page 21	RS422 Connections
Page 22	Aux 1 GPI Input connections + misc
Page 23	Aux 2 GPI Output connections + misc
Page 24,25	RS422 Protocol for the ADPm-1000
Page 26	Translation Table for the ETSI Wide Screen Signalling system (ETS 300 294) when used with the ADPm-1000

ADPm-1000 ●●●●●●●●●●

Overall Specification ●●●●●

Physical Format	Host PCB Subsystem for fitting into an Eyeheight Uni-Box System.
Power Requirements	+5V at 1.5 Amp, supplied from the Uni-Box. -5V at 100 mA, supplied from the Uni-Box.
General Features	<ul style="list-style-type: none"> ●Video Index Extraction and Re-insertion. ●Widescreen Signal Generation and Extraction. ●In Vision WSS/VI Reader (20 Chr) ●“eYeIdentify” Eyeheight Aux data Source Identification System. (Order code ID-1000) ● Monitoring Quality PAL/NTSC output ** note 1 ●Downstream EDH Re-insertion ●Fail-safe Dual Contact Relay bypass from input to output 2 on power failure.
Local Control	Standard Eyeheight Uni-Panel (UP-1000)
Remote Control	Standard Eyeheight Uni-Panel situated up to 50M remotely using RS422 control with power from the Uni-Box.
Accessories	<ul style="list-style-type: none"> ●The ADPm-1000 PCB requires a spare slot in an Eyeheight Uni-Box (UB-1000) ●Control is by Eyeheight Uni-Panel (UP-1000).
Input	270 Mbit Serial Digital with active loop through. Input R.L <=-15dB, 75 Ohm
Outputs	2 off Main Serial Digital outputs (BNC) (Output 1 is “Fail Safe”). 75 Ohm.
Other Connections	RS422 control 9W D type (female) GPI and Audio connections (15W D-Type fem)

Technical Specification

ADPm-1000

SDI Input	<p>1 Off CCIR 601 Component 525/625, 10 bits data, Scrambled NRZI, 270 Mb/s. (Complies with SMPTE 259M and CCIR 656.</p> <p>Input Impedance 75 Ohm Input Level 800mV +/- 80mV (Pk-Pk) at Signal Source. Return Loss >=-15dB from 1MHz to 270MHz Equalisation Minimum of 150 Metres PSF 1/2</p>
SDI Output	<p>2 off CCIR 601 Component 525/625, 10 bits data, Scrambled NRZI, 270 Mb/s. Complies with SMPTE 259M and CCIR 656.</p> <p>Output 1 Equipped with Relay Bypass from Input For Power failsafe situations. Output 2 Standard O/P not equipped with the above. Output 3 Input 1 Active Loophthrough. Output Impedance 75 Ohm Output Level 800mV +/- 80mV (Pk-Pk) at BNC. Return Loss >=-15dB from 1MHz to 270MHz EDH Option Menu for EDH Re-Insertion</p>
Analogue Video Outputs**note1	<p>4 BNC Connectors with 3 Soft Menus Selecting the Monitoring Quality Video Outputs as follows:</p> <p><u>Menu--CVBS/Y/U/V:</u> CVBS PAL/NTSC Auto Configure. 0.7 Volt Pk-Pk Luma +/- 3% Fully Adjustable Chroma by menu Colour Burst 0.3V Pk-Pk +/-5% Sync 0.3V Pk-Pk +/- 5%</p>
Processing	<p>Video Index Extraction and Re-insertion. Widescreen Signal Generation and Extraction. In Vision VI/WSS Reader (20 Chr..) "eYeDentify" Eyeheight Source Identification System. (ID-1000)</p>
System Delay	<p>System Delay is constant and less than 0.5uS. If used with synchronising reference input, the output is timed to the reference input.</p>
Bypass Mode	<p>Full 10 Bit Bypass mode with all Picture and Auxiliary data being Bypassed.</p>
GPI	<p>8 off Fully Opto-Coupled GPI Inputs 8 off output GPI, Relay Change over system.</p>
Power Fail/Error Tally	<p>1 off Changeover relay for Power fail or other Fail options.</p>
RS422	<p>RS422 control 9W D type (female) Min 50 Metres Operation Power for Remote Uni-panel optionally down Pin 5</p>

Note 1. This is only available on issue 2 optional versions and later issues.

Overall ADPm-1000 System

The Eyeheight ADPm-1000 Auxiliary Data Processor Has been designed to fulfil as many functions as possible involving Vertical and Horizontal Interval Data. These include:

- Video Index Extraction and Re-insertion.
- Widescreen Signal Generation and Extraction.
- In Vision VI/WSS Reader (20 Chr)
- “eYeDentify” Eyeheight Aux data Source Identification System. (ID-1000)

The product is also capable of many “Small Quantity” Custom Solutions for Auxiliary data. Please Contact Eyeheight if custom solutions are required.

A block diagram of the functionality of the ADPm-1000 is shown overleaf. The overall principle of operation is as follows:

The unit takes in two sets of information in a form, which has been coded, dependent on the selected “Date Stream”. The input selector is represented by the 5 way switch in the diagram Fig 1. These two sets of information are

1. The Aspect ratio information (AR) as defined in SMPTE 186, Class 1.1. Essentially there are 8 possible variants of Aspect Ratio and line standard. These are shown in Table 1.
2. The Active Format Descriptor (AFD). This describes the way in which a picture may be represented on a 4/3 or 16/9 glass. Again there are 8 variants of this. These are shown in Table 2.

AR	LCD Mnemonic	Meaning
0	<no info>	There is no information about the video origin
1	<525 4/3>	525 line standard video, 4/3 Aspect Ratio
2	<625 4/3>	625 line standard video, 4/3 Aspect Ratio
3	<reserved 1>	Reserved for future use
4	<Reserved 2>	Reserved for future use
5	<525 16/9>	525 line standard video, 16/9 Aspect Ratio
6	<625 16/9>	625 line standard video, 16/9 Aspect Ratio
7	<reserved 3>	Reserved for future use

Table 1. AR Information

AFD	LCD Mnemonic	Meaning
8	<As Cod. Fr>	Active region is the same as the coded frame
9	<4/3>	4:3
10	<16/9>	16:9
11	<14/9>	14:9
12	<Reserved 1>	Reserved for future use
13	<4/3 sp 14/9>	4:3 with shoot-and-protect a 14:9 centre
14	<16/9 sp 14/9>	16:9 with shoot-and-protect a 14:9 centre
15	<16/9 sp 4/3>	16:9 with shoot-and-protect a 4:3 centre

Table 2. AFD Information

The “Control” menu is used to select the Input data stream. The input options are as follows:

Video Index (VI)

If the Input data stream is selected to be the VI (Video Index), then the ADPm-1000 will extract the above Information from the Video Index on the Main Input SDI video, on lines 11 and 324. The Extracted video Index is of the UK Modified form as specified in ARDSPEC 1, Specification for Video Index Insertion Equipment. Document by Nick Tanton (BBC), Andy Cooper (BDB), Kevin Burrows (Channel 4) and Mike Elgey (ITV).

The Information may then be read from the LCD Display using the ipAFD and ipAR Menus. The information will also be used to regenerate a new Video Index, and a new Wide Screen Signalling, line 23 Data if they are enabled. The Information may also be extracted in the form of Output GPI's or Interrogated by the RS422 port.

Wide Screen Signalling (WSS)

If the Input data stream is selected to be the WSS (Wide Screen Signalling), then the ADPm-1000 will extract the above Information from the WSS on the Main Input SDI video, on line 23. The Extracted WSS can be either of the UK Modified form as specified in L23_SPEC.DOC. or of the original ETSI, ETS 300 294 Specification. (This can be selected on a soft menu option)

The Information may then be read from the LCD Display using the ipAFD and ipAR Menus. The information will also be used to regenerate a new Video Index, and a new Wide Screen Signalling, Line 23 Data if they are enabled. The Information may also be extracted in the form of Output GPI's or Interrogated by the RS422 port.

On Screen VI/WSS Reader

Also Incorporated on the ADP-1000m (Not on the ADP-1000) is an In vision Character burner which will show the AFD and AR status burnt-in on the Screen

General Purpose Interface (GPI)

If the Input data stream is selected to be the GPI, then the ADPm-1000 will extract the above Information from the Input GPI Port on the 15Way Connector at the rear of the PCB. The mapping of this may vary depending on the customer's requirements

The Information may then be read from the LCD Display using the ipAFD and ipAR Menus. The information will also be used to regenerate a new Video Index, and a new Wide Screen Signalling, Line 23 data if they are enabled. The Information may also be extracted in the form of Output GPI's or Interrogated by the RS422 port.

Control Panel (Panel)

If the Input data stream is selected to be the Control Panel, then the ADPm-1000 will extract the above Information from the settings on the UNI-Panel in the soft menus opAR and opAFD.

The Information may then be read from the LCD Display using the ipAFD and ipAR Menus. The information will also be used to regenerate a new Video Index, and a new Wide Screen Signalling, Line 23 Data if they are enabled. The Information may also be extracted in the form of Output GPI's or Interrogated by the RS422 port.

RS422 Communications port (RS422)

If the Input data stream is selected to be the RS422, then the ADPm-1000 will extract the above Information from the communication on the RS422 port. The protocol is given at the end of this manual.

The Information may then be read from the LCD Display using the ipAFD and ipAR Menus. The information will also be used to regenerate a new Video Index, and a new Wide Screen Signalling, Line 23 Data if they are enabled. The Information may also be extracted in the form of Output GPI's or Interrogated also by the RS422 port.

Block Diagram of the ADPm-1000 functionality as of 28 October 1998

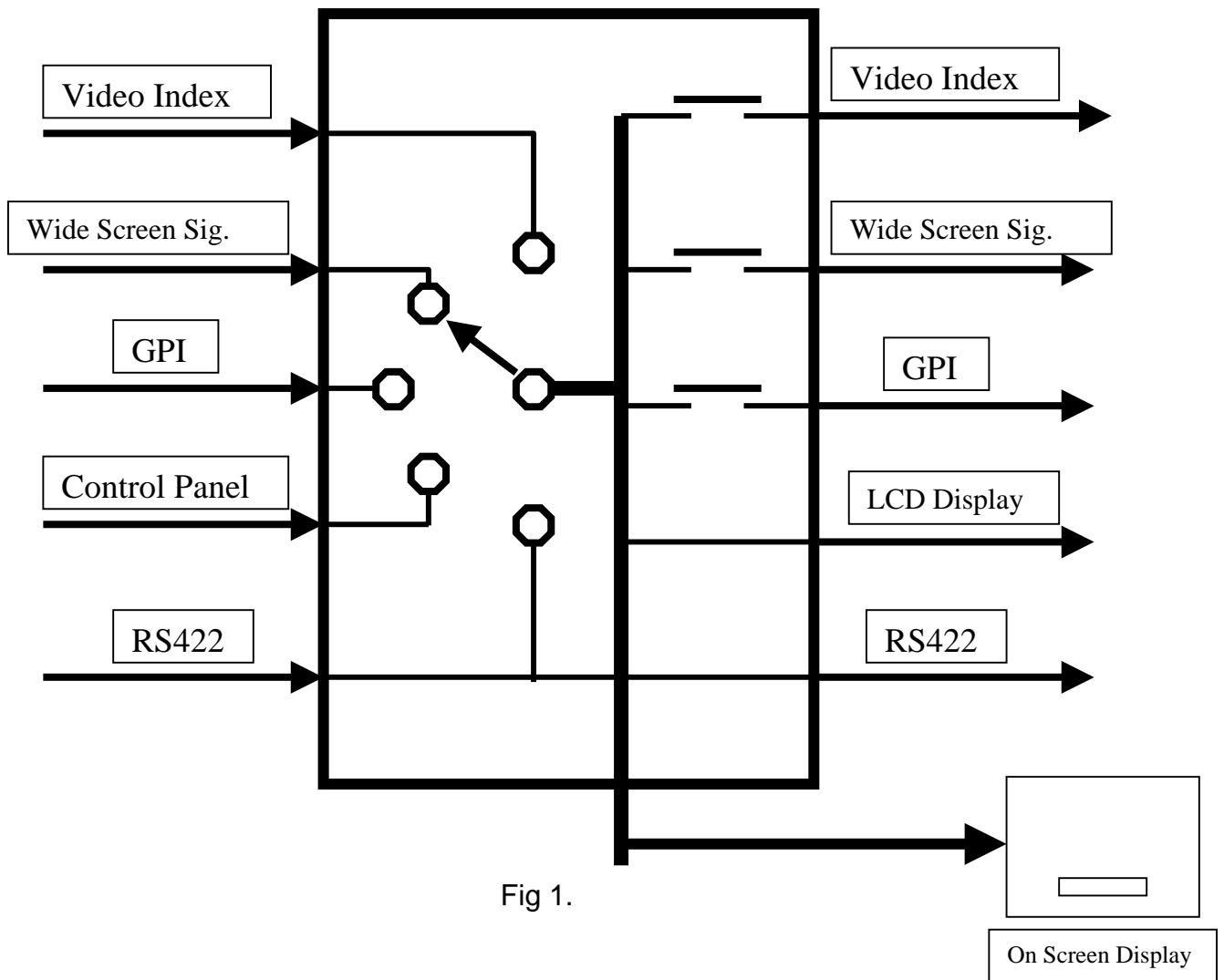

Eyeheight Uni-System Generic Menu System

All Eyeheight UNI-Box products (The ADPm-1000 Included) have a generic menu system. Generally speaking the “Menu” Digipot (Right hand Digipot) is used to select a new menu. Moving the “Menu” Digipot will never cause any parameters within the unit to change (It is always “Safe” to move this). This Digipot is used to “Browse” the state of the system.

After a menu has been selected the “Adjust” Digipot can be used to change a System Parameter.

Generally speaking the Front panel Buttons (Except for the “Left most” button) are used as “Quick find and set-up”. Normally all the functions on the “Button pushes” are repeated in the “Soft Menus”.

The left most button is used to select control between the two possible PCB units within the UNI-Box. (See the UNI-Panel/UNI-Box Manual for further details).

UNI-Panel Set-up

The Uni-Panel has a number of set-up features that are important to know about. These set-up features are permanently stored in EE-prom such that once they are set up there should be little or no need to change them again.

Pressing certain keys on the Uni-Panel while the unit is being powered up activates the set up modes. If the Uni-Panel is locally situated on the front of a Uni-Box, then the whole Uni-box must be re-powered while the set-up keys are pressed in. If the Uni-panel is remotely sited, then it may be easier to re-power the panel only by disconnecting and reconnecting the 9W D type, while the set-up keys are being pressed.

In the following text the terminology “**slot 0**” refers to the PCB system on the Right Hand side looking from the **rear** of the Uni-Box.

The terminology “**slot 1**” refers to the PCB system on the Left-Hand side looking from the **rear** of the Uni-Box.

First Birthday:

Pressing switches 1 and 10 together when power-up happens, will cause a 1st Birthday to occur. This will clear the EE-prom to 00h, **and consequently put the panel into ‘Local’ mode and lose all the LK-1000 start-up data and the user set device names.** Re-powering will however put the system into a sensible default mode.

After EE-Prom is cleared, the message ‘EE-OK’ will appear on the LCD display and the host systems must be restarted by a total power down.

Protocol Change:

Pressing switches 3 and 8 together when power-up happens, will cause the panel protocol to toggle between 'Eyeheight 2 wire local talk' and RS422. If the panel is remotely sited 'RS422' is required. If the panel is on the front of a Uni-Box then 'Local' is required.

Slot Identification Text:

Pressing switches 5 and 6 together when power-up happens, will cause a mode to be entered such that the "user slot text" can be changed and stored in EE-prom.

The Text is displayed when a user uses SW 1 to switch between slot 0/1. This announces that now you are controlling, for example 'Channel 1 Bug' or 'Channel 3 Ident'.

The default text after a first birthday is 'Dev 1' for slot 0 and 'Dev 2' for slot 1.

To change the text for slot 0, enter this mode by powering up with sw 5 and 6 pressed. You will now see the Slot 0 text (Dev 1) adjust character under the underscore by moving the 'adj.' digipot. To move the underscore, use the 'menu' digipot.

When you have completed the slot 0 text, press sw 10 (Flashing led). this will then do the same for the slot 1 text. When this is complete press SW 10 and after a few seconds re-power the system.

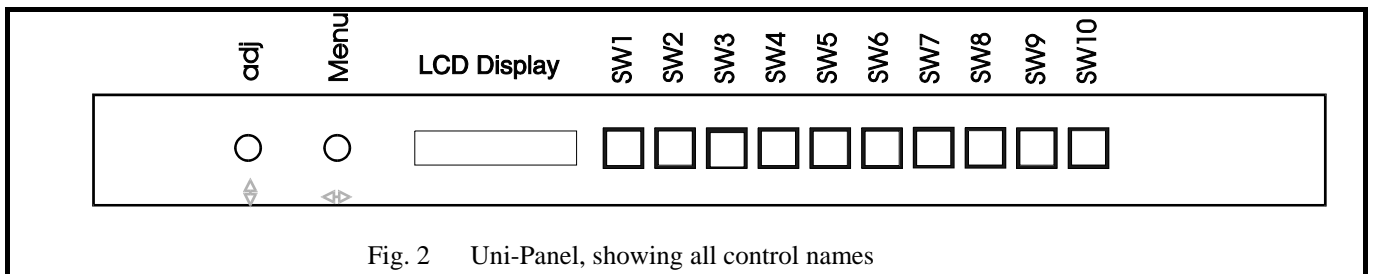

Fig. 2 Uni-Panel, showing all control names

ADPm-1000 Soft Menu List

The following is a list of the UNI-System Soft set-up Menus for the ADPm-1000

Soft Menu	Function
Ip afd=	AFD read from the <u>INPUT</u> Data Stream. (Intended aspect ratio of active region) The meaning of each setting is described below
8 <As Cod. Fr>	Active region is the same as the coded frame
9 <4/3>	4:3
10 <16/9>	16:9
11 <14/9>	14:9
12 <Reserved 1>	Reserved for future use
13 <4/3 sp 14/9>	4:3 with shoot-and-protect a 14:9 centre
14 <16/9 sp 14/9>	16:9 with shoot-and-protect a 14:9 centre
15 <16/9 sp 4/3>	16:9 with shoot-and-protect a 4:3 centre
<not found>	Incoming data stream either not found or not valid (e.g if incoming data stream is video index, then either the video index is not embedded in the incoming SDI video signal, or it is not correctly formatted)
Ip ar=	“Aspect Ratio” read from the <u>INPUT</u> Data Stream in the generic form as given in RP186 SMPTE specification (Class 1.1) (Aspect ratio of the source) The meaning of each setting is described below
<no i nfo>	There is no information about the video origin
<525 4/3>	525 line standard video, 4/3 Aspect Ratio
<625 4/3>	625 line standard video, 4/3 Aspect Ratio
<reserved 1>	Reserved for future use
<Reserved 2>	Reserved for future use
<525 16/9>	525 line standard video, 16/9 Aspect Ratio
<625 16/9>	625 line standard video, 16/9 Aspect Ratio
<reserved 3>	Reserved for future use
<not found>	Incoming data stream either not found or not valid (e.g if incoming data stream is video index, then either the video index is not embedded in the incoming SDI video signal, or it is not correctly formatted)
op afd=	This is the manual CONTROL PANEL setting of the output (Generated) AFD. (This setting applies ONLY when the “Control” Soft menu is set to “Panel”) The meaning of each setting is described below
0 <As Cod. Fr>	Active region is the same as the coded frame
1 <4/3>	4:3

2 <16/9>	16:9
3 <14/9>	14:9
4 <Reserved 1>	Reserved for future use
5 <4/3 sp 14/9>	4:3 with shoot-and-protect a 14:9 centre
6 <16/9 sp 14/9>	16:9 with shoot-and-protect a 14:9 centre
7 <16/9 sp 4/3>	16:9 with shoot-and-protect a 4:3 centre
op ar=	This is the manual CONTROL PANEL setting of the output (Generated) Aspect Ratio as defined in Class 1.1 of SMPTE RP186. (This setting applies ONLY when the "Control" Soft menu is set to "Panel". The meaning of each setting is described below
<no i nfo>	There is no information about the video origin
<525 4/3>	525 line standard video, 4/3 Aspect Ratio
<625 4/3>	625 line standard video, 4/3 Aspect Ratio
<reserved 1>	Reserved for future use
<Reserved 2>	Reserved for future use
<525 16/9>	525 line standard video, 16/9 Aspect Ratio
<625 16/9>	625 line standard video, 16/9 Aspect Ratio
<reserved 3>	Reserved for future use
Read from	This menu defines the control mechanism for defining the output (Generated) AFD and AR.
<panel >	The control of the generated data (WSS, VI, GPI...) is defined by the settings set by the Eyeheight control panel in the menus OP AFD and OP AR
<GPI >	The control of the generated data (WSS, VI, GPI...) is defined by the settings set by the Input GPI's. The mapping of the GPI's depends on the Software. The user can specify their own particular mapping and this will be factory programmed. The two most common GPI Mappings are given at the end of this manual.
<rs422>	The control of the generated data (WSS, VI, GPI...) is defined by the communication via the RS422 Port. The protocol for this is given at the end of this manual.
<vi >	The control of the generated data (WSS, VI, GPI...) is defined by setting of the incoming UK modified Video Index signal contained within the incoming SDI video on lines 11 and 324.
<WSS>	The control of the generated data (WSS, VI, GPI...) is defined by setting of the incoming UK modified Wide Screen Signalling data contained within the incoming SDI video on line 23

V i n x i n s e r t = o n / o f f	This defines the State of the generated Video Index Signal. It is either “On” (Inserted on lines 11 and 324) or “Off” (Not inserted at all)
W S S i n s e r t = o n / o f f	This defines the State of the generated Wide Screen Signalling data. It is either “On” (Inserted on line 23) or “Off” (Not inserted at all)
O u t p u t g p i = o n / o f f	This defines the State of the Output GPI Relays They are either “On” (Reflecting a Factory programmed GPI mapping which is controlled by the selected data stream in the “Control” Soft menu – See output GPI’s at the end of this manual) or “Off” (All GPI’s are in their electrically “Relaxed” State.)
I n p u t f a t a l = o n / o f f	This menu defines whether an input DATA error in the data stream selected by the “Control” soft menu will cause the “Error Alarm Relay” to activate. Examples of errors might be as follows: <i>Incoming Video index checksum incorrect.</i> <i>RS422 control error occurred</i> <i>Incoming WSS Parity error.</i> (Note that in each of these cases, for an error to occur, the “Control” Menu must be selected for the relevant input data stream – in this case VI,RS422 and WSS Respectively)
L a s t e r r o r =	This menu will automatically be selected when an error occurs in the incoming video. It is accompanied by a flashing LED on the “Error” Button on the UNI-Panel and also the “Error Alarm Relay” will activate. To “Reset” the error alarm after an error has occurred the user must press the “Error” Button on the UNI-Panel.
< n o n e >	No error has occurred since the “Error” Button on the UNI-Panel has been pressed.
< i n p u t >	An error in the Input Video Synchronisation words has been seen.
< r e f >	An error in the Reference Video Synchronisation words has been seen. If this occurs the unit will automatically revert to “Minimum Input Delay” mode, and ignore the reference <u>until the “Error” Button is pressed on the UNI-Panel.</u> The unit will then again attempt to resynchronise the video to the incoming reference. If no reference is provided to the unit on power up, the unit will assume that the user will not be providing a reference input and will not keep flagging this as an error.

<data>	This error will only occur if the "Input Fatal" Menu is set to ON, and indicates that an error has occurred in the input data stream. (See Input Fatal menu for a full explanation)
Show vi =on/off	This is a diagnostic menu only. With "Show VI" ON, the video index signal on lines 11 and 324 will become visible on the video monitor as a corresponding luminance signal on lines 11 and 324. The state of this menu is NOT remembered on power down. The unit will always power up with this menu OFF.
Ena wss gpi =on/off	This menu enables Input GPI 1-4 to operate in such a way as for the Generated WSS Signal to incorporate them in its protocol. (4 bits are reserved on the UK L23_spec.doc WSS specification for GPI use)
WSS=	
UK_L23_Spec	This selects the Modified UK L23_spec for the WSS Signal which includes bit mappings for the AR and the AFD.
ETSI 294_Spec	This selects the Original ETSI Specification for WSS (PAL+) which has bit mappings from 0-7 for Aspect Ratio. Because the definitions of the bit mappings are not the same as UK AFD Mapping, they are represented BY the UK AFD Mappings and a translation table is given at the end of this manual.
GPI 1 = n	<p>This can be set to a number between N=0 and N=15. These settings determine the effect of the GPI inputs 1→8 when they are selected as the input stream (i.e READ FROM GPI is selected). The meaning of the number "N" is as follows:</p> <p>GPI 1=0 AFD=8, AR=2 (4:3) GPI 1=1 AFD=9, AR=2 (4:3) GPI 1=2 AFD=10, AR=2 (4:3) GPI 1=3 AFD=11, AR=2 (4:3) GPI 1=4 AFD=12, AR=2 (4:3) GPI 1=5 AFD=13, AR=2 (4:3) GPI 1=6 AFD=14, AR=2 (4:3) GPI 1=7 AFD=15, AR=2 (4:3) GPI 1=8 AFD=8, AR=2 (16:9) GPI 1=9 AFD=9, AR=2 (16:9) GPI 1=10 AFD=10, AR=2 (16:9) GPI 1=11 AFD=11, AR=2 (16:9) GPI 1=12 AFD=12, AR=2 (16:9) GPI 1=13 AFD=13, AR=2 (16:9) GPI 1=14 AFD=14, AR=2 (16:9) GPI 1=15 AFD=15, AR=2 (16:9)</p>

.....GPI 2 ...→... 8 " " " "	The next 7 menus are the same as above except for GPI's 2→8
------------------------------------	--

ADPm-1000 Button Push Functions

Switch #	Label	Function
Switch 1	ADPm1/ADPm2	This button selects between the Two possible UNI-Box series products within the UB-1000 UNI-box Chassis. Note - one of these labels may be different if a different UNI-Box product is loaded into the chassis. E.g. ADPm-1/LK-1, if an Eyeheight LK-1000 Logokeyer is loaded into the spare slot.
Switch 2	Read AFD	Pressing this button selects the ipAFD Soft menu. This will show the Input Stream Active Format Descriptor on the LCD Display. (See Soft Menu Description)
Switch 3	Read AR	Pressing this button selects the ipAR Soft menu. This will show the Input Stream Aspect Ratio on the LCD Display. (See Soft Menu Description)
Switch 4	Read From	Pressing this button selects the "Control" Soft menu. This enables the user to set up the Input Stream from which the AR and AFD are read from, i.e VI/WSS/RS422/GPI/Panel
Switch 5	Line 23 Blank	When this is on, the incoming L23 is blanked
Switch 6	Set AFD	Pressing this button selects the opAFD Soft menu. This enables the user to change the "Panel Setting" of the Active Format Descriptor using the "Adjust" Digipot. <u>Note that this will only set the output (WSS/VI/GPI) if the "Control" Menu is selected for "Panel". (See Soft Menu Description)</u>
Switch 7	Set AR	Pressing this button selects the opAR Soft menu. This enables the user to change the "Panel Setting" of the Aspect Ratio using the "Adjust" Digipot. <u>Note that this will only set the output (WSS/VI/GPI) if the "Control" Menu is selected for "Panel". (See Soft Menu Description)</u>
Switch 8	Display Reader	This will toggle on and off the On-Screen VI/WSS reader Display.
Switch 9	Error Rst	The LED in this switch will "Flash" if an error occurs. The unit will also set an "Alarm" Tally relay and go to the "Last Error" Soft Menu. Pressing this switch will cancel the alarm if the error has been rectified.
Switch 10	Bypass	If this button is pressed the unit will Remove all inserted Ancillary Data Insertion effectively bypassing the unit. While the system is in bypass the LED in the button will "Blink". In versions of this unit with GPI Mapping 3

		(usually for a Drake Automation system) When in GPI Control this function is on over-ride and will bypass only when an AFD value of Zero is received.
--	--	---

Assembly of the ADPm-1000 PCB into a Uni-box.

Normally a system will be assembled and set-up at the factory, However a user may wish to move cards from one Uni-Box to another and change user settings from time to time.

The procedure for assembling a ADPm-1000 into a Uni-Box is as follows:

1)....	Remove the mains from the Uni-Box.
2)....	Remove the blank rear cover, by unscrewing the six M2.5 screws at the rear slot. If there is already one PCB Subsystem in the rear of the unit there will only be one rear blank cover over Slot 1 and this will be on the LEFT looking from the rear of the unit. If for and reason there are NO PCB Subsystems in this Uni-Box, then the ADPm-1000 MUST be inserted into Slot 0, which is the Right Hand slot looking from the rear.
3)....	Insert the ADPm-1000 PCB into the slot and affix the six M2.5 screws. Take care not to snag the Coaxial cables as you do this, the connections are delicate.
4)....	Re-apply the mains to the Uni-Box and the systems will start-up.
5)....	On start-up you should now get the message "ADPm-1000 V4.xx" either once or twice depending on whether there are one or two ADPm-1000 PCBs in this Uni-Box. On the first power-up you should also observe the message "EE-upload" rather than the usual EE-download message on the LCD Display of the Uni-Panel.
6)....	Refer to the "Slot Identification text" section of this manual under "Uni-Panel" set-up for instruction on how to personalise the name of the Auxiliary Data Processor (e.g. "WSS 1 Ch3")

Fig 1. Rear Panel Connections

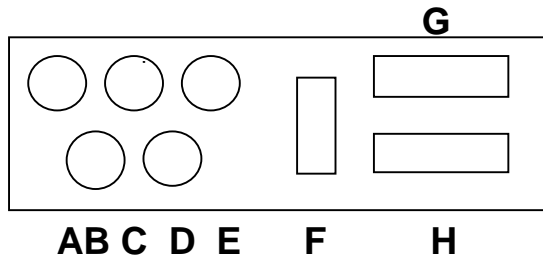

**Rear Termination Panel
ADPm-1000**

A	SDI Input (Power Fail Bypass Input)
B	Input Loop
C	SDI Output #1 (Same as D but no Relay Bypass)
D	SDI Output #2 (Power Fail Bypass Output)
E	Optional CVBS Output
F	RS422 Interface
G	GPI Output Connections
H	GPI Input Connections

User Jumpers on the ADPm-1000 PCB

The Following is a list of the User Jumpers on the Auxiliary Data Processor PCB Assembly.

Jumper	Function Of Jumper	Status
LK1	Video Firmware enable X2	Must Jumper
LK2	Video Firmware enable X1	Must Jumper
LK3	Power for Diagnostic Pod	DO NOT Jumper
LK4	Processor Reset	Do Not Jumper
LK5	Internal Power Select for GPI 1 Input	User Selectable
LK6	Internal Power Select for GPI 2 Input	User Selectable
LK7	Internal Power Select for GPI 3 Input	User Selectable
LK8	Internal Power Select for GPI 6 Input	User Selectable
LK9	Internal Power Select for GPI 5 Input	User Selectable
LK10	Internal Power Select for GPI 4 Input	User Selectable
LK11	Internal Power Select for GPI 7 Input	User Selectable
LK12	Internal Power Select for GPI 8 Input	User Selectable
LK13	Computer reset for X3	Must Jumper
LK14	Computer reset for X2	Must Jumper
LK15	Computer reset for X1	Must Jumper
LK16	+12V enable for External Uni-Panel	User Selectable
LK17	AES Audio Output Configuration **	User Selectable
LK18	AES Audio Output Configuration **	User Selectable
LK19	AES Audio Output Configuration **	User Selectable
LK20	AES Audio Output Configuration **	User Selectable
LK21	AES Audio Output Configuration **	User Selectable
LK22	AES Audio Output Configuration **	User Selectable
LK23	AES Audio Output Configuration **	User Selectable
LK24	Video Firmware enable X3	Must Jumper
LK25	GPI Output 4 Polarity	User Selectable
LK26	GPI Output 2 Polarity	User Selectable
LK27	GPI Output 3 Polarity	User Selectable
LK28	GPI Output 1 Polarity	User Selectable
LK29	GPI Output 5 Polarity	User Selectable
LK30	GPI Output 7 Polarity	User Selectable
LK31	GPI Output 6 Polarity	User Selectable
LK32	GPI Output 8 Polarity	User Selectable
LK33	Analogue Output Sync on Y/G Enable	User Selectable
LK34	Timecode Super on CVBS output	User Selectable
LK35	Re-insert EDH Enable/Disable	User Selectable

GPI Outputs for AFD 8-15 in-line mapping

AFD	RLY0	RLY1	RLY2	RLY3	RLY4	RLY5	RLY6	RLY7
0	ON	OFF	OFF	OFF	OFF	OFF	OFF	OFF
1	OFF	ON	OFF	OFF	OFF	OFF	OFF	OFF
2	OFF	OFF	ON	OFF	OFF	OFF	OFF	OFF
3	OFF	OFF	OFF	ON	OFF	OFF	OFF	OFF
4	OFF	OFF	OFF	OFF	ON	OFF	OFF	OFF
5	OFF	OFF	OFF	OFF	OFF	ON	OFF	OFF
6	OFF	OFF	OFF	OFF	OFF	OFF	ON	OFF
7	OFF	OFF	OFF	OFF	OFF	OFF	OFF	ON

ADPm-1000 PCB RS422 Interface (F)

This is the Pinout for the 9W D type on the ADPm-1000 PCB

Pin 1	Ground 0V
Pin 2	Tx-
Pin 3	Rx+
Pin 4	
Pin 5	+12 V Uni-panel power
Pin 6	
Pin 7	Tx+
Pin 8	Rx-
Pin 9	Ground 0V

Pin out for Aux1 Connection on the Eyeheight ADPm-1000 (H)

PIN	FUNCTION
------------	-----------------

1	Input GPI #1
14	Input GPI #1 (Used for Balanced operation only)
2	Input GPI #2
15	Input GPI #2 (Used for Balanced operation only)
3	Input GPI #3
16	Input GPI #3 (Used for Balanced operation only)
4	Input GPI #4
17	Input GPI #4 (Used for Balanced operation only)
5	Input GPI #5
18	Input GPI #5 (Used for Balanced operation only)
6	Input GPI #6
19	Input GPI #6 (Used for Balanced operation only)
7	Input GPI #7
20	Input GPI #7 (Used for Balanced operation only)
8	Input GPI #8
21	Input GPI #8 (Used for Balanced operation only)
9	Error Relay (Common)
22	Error Relay (Fail)
10	Error Relay (OK)
23	Linear Timecode Input +
11	Linear Timecode Input -
24	Gnd
12	Linear Timecode Output (regenerated)
25	Gnd
13	Gnd

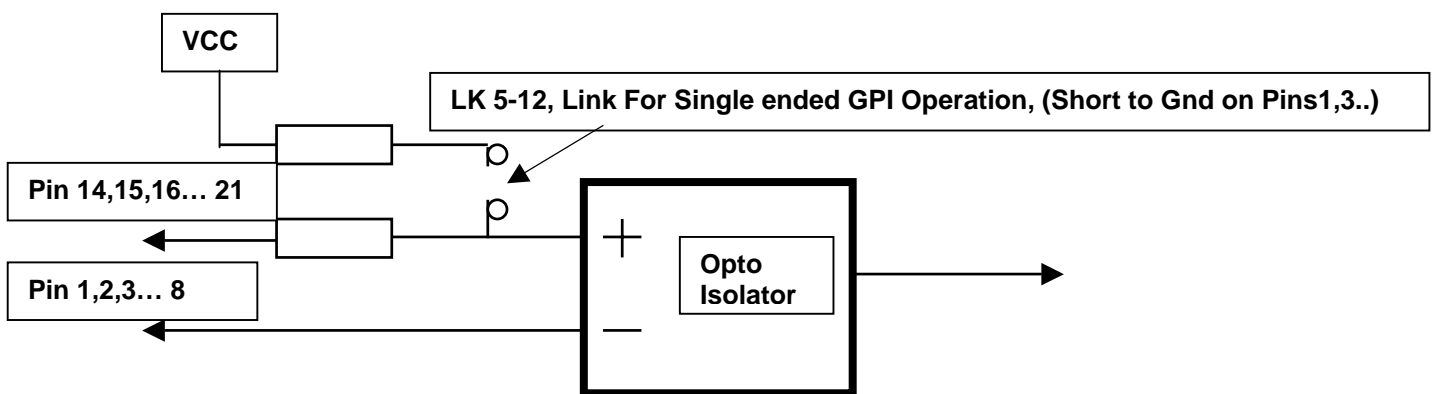

Diagram Of the GPI Input Stage

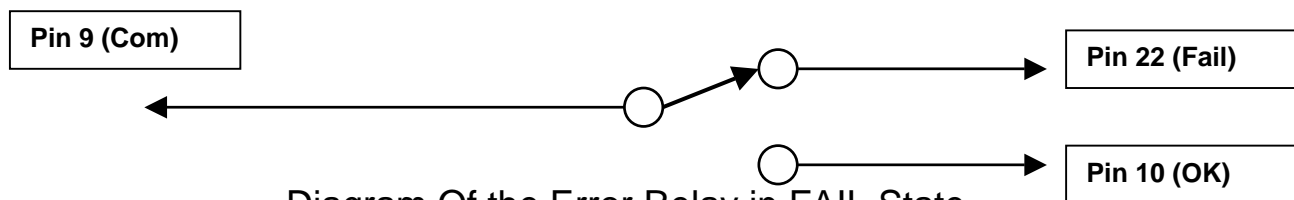

Diagram Of the Error Relay in FAIL State

Pin-out for Aux2 25W D type Connector on the ADPm-1000

PIN	FUNCTION
1	Output GPI #1 Relay Terminal 1

14	Output GPI #1 Relay Terminal 2
2	Output GPI #2 Relay Terminal 1
15	Output GPI #2 Relay Terminal 2
3	Output GPI #3 Relay Terminal 1
16	Output GPI #3 Relay Terminal 2
4	Output GPI #4 Relay Terminal 1
17	Output GPI #4 Relay Terminal 2
5	Output GPI #5 Relay Terminal 1
18	Output GPI #5 Relay Terminal 2
6	Output GPI #6 Relay Terminal 1
19	Output GPI #6 Relay Terminal 2
7	Output GPI #7 Relay Terminal 1
20	Output GPI #7 Relay Terminal 2
8	Output GPI #8 Relay Terminal 1
21	Output GPI #8 Relay Terminal 2
9	AES Audio Input 1 +
22	AES Audio Input 1 -
10	AES Audio Input 2 +
23	AES Audio Input 2 -
11	AES Audio Output 1 +
24	AES Audio Output 1 -
12	AES Audio Output 2 +
25	AES Audio Output 2 -
13	Gnd

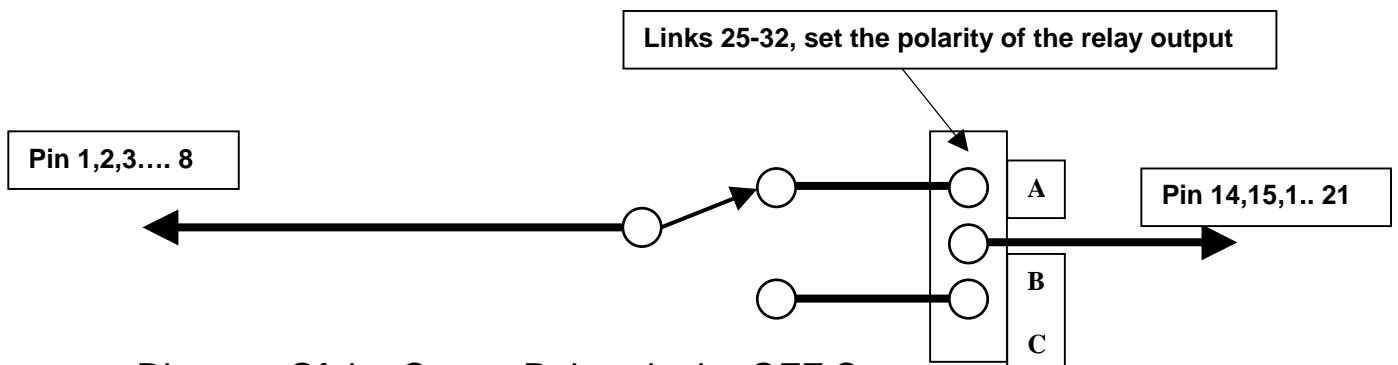
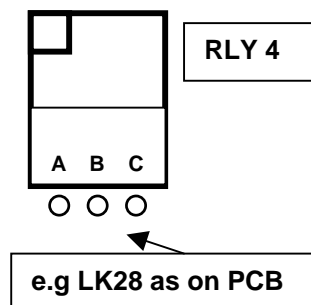

Diagram Of the Output Relays in the OFF State
 Below shows the PCB Layout of a typical GPI Relay with Link



RS422 Protocol for the ADPm-1000

On power up of an ADPm-1000 System, the ADPm-1000 will look for a UNI-Panel Connection on the RS422 port. It does this by sending an ASCII "X", to which the UNI-Panel replies with an ASCII "x". If no UNI-Panel is found, the

unit assumes that this port may be used for an RS422 with the following protocol:

Line Characteristics – 19.2 K baud, 2 stop bits, no parity, RS422
The commands and responses are composed of ASCII characters only.
<CR>= Hex 0D

Configuration Setting Command (From Host to ADPm-1000)

To set the configuration of the ADPm-1000 the following command is used:
SETab<CR> Where nn is a 2 digit ASCII number defined as follows:

a	AFD	AR
0	b	No Info
1	b	4:3 525
2	b	4:3 625
3	b	Res 1
4	b	Res 2
5	b	16:9 525
6	b	16:9 625
7	b	Res 3

b	AFD	AR
0	As Coded Frame	a
1	4:3	a
2	16:9	a
3	14:9	a
4	Reserved for future use	a
5	4:3 with shoot-and-protect a 14:9 centre	a
6	16:9 with shoot-and-protect a 14:9 centre	a
7	16:9 with shoot-and-protect a 4:3 centre	a

The ADPm-1000 will reply with:

OKab<CR> to signal acceptance of the new configuration ab

If the ADPm finds an error in the command setting it will reply with:

ERnn<CR> Where nn is the error number.

Configuration Sensing Command (From Host to ADPm-1000)

To get the ADPm-1000 to report its current setting the following command is used:

SENSE<CR>

The ADPm-1000 will reply with:

CCcdab<CR> Where ab is a 2 digit ASCII number defined in the above table, c=0 if no SDI is input to the unit and=1 if there is a valid SDI Input, d=last error code as defined below.

d	Last Error meaning
0	No error has occurred since the last error reset
1	This error code no longer exists
2	SDI Input failure
3	Transport data failure (WSS or Video Index)

If the ADPm finds an error in the command setting it will reply with:
ERnn<CR> Where nn is the error number.

Error Codes

The following is a list of error codes for the RS422 Protocol:

Error Code nn	Meaning of error
00	Command Overrun (no <CR> found after 10 Characters)
01	First Character in command not "S" or "R"
02	Second Character in command not "E"
03	Third Character in command not "T" or "N"
04	Fourth Character in command "SENSE" is not "S"
05	Fifth Character in command "SENSE" is not "E"
06	Fourth Character in "SET" command not "0 to 7"
07	Fifth Character in "SET" command not "0 to 7"

Reset Last Error Command:

Send R,<CR> to reset the last error (Same as pressing ERR.RST Button)

Guaranteed Automation Reset Method:

Sending a <CR> at any time will terminate a command at that point. An appropriate error message will occur from the ADPm-1000 and the ADPm-1000 buffers will be cleared to receive a new command.

Translation Table for the ETSI Wide Screen Signalling system (ETS 300 294)

Aspect ratio Information (Bits 0,1,2 of the 14 data bits)
As represented on the LCD Display of the ADPm-1000

ADPm-1000 Representation	ETSI ETS 300 294 Representation
<As Cod. Fr>	Full format 4:3
<4/3>	Box 14:9 Centre
<16/9>	Box 14:9 Top
<14/9>	Box 16:9 Centre
<Reserved 1>	Box 16:9 Top
<4/3 sp 14/9>	Box >16:9 Centre
<16/9 sp 14/9>	Full format 4:3 (Shoot and protect 14:9 Centre)
<16/9 sp 4/3>	Full format 16:9 (Anamorphic)